

# TOWN OF CULPEPER

## Facilities Standards Manual

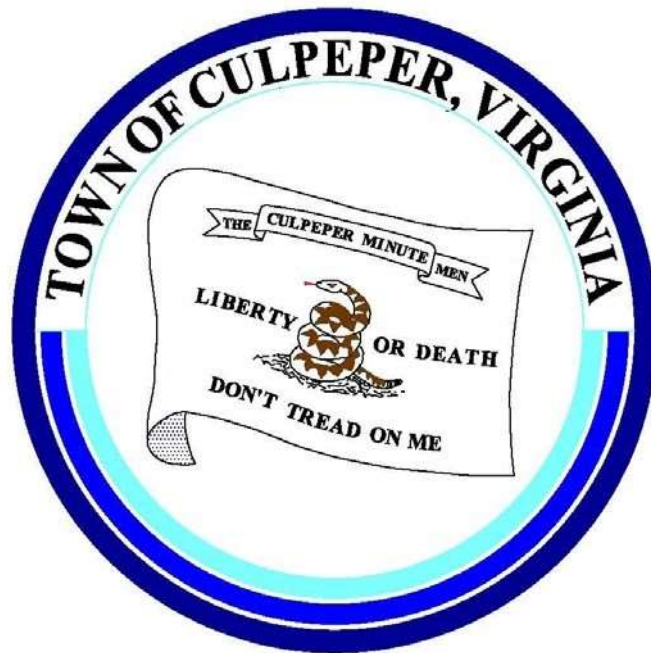

PLANNING & COMMUNITY DEVELOPMENT  
400 S. MAIN STREET, SUITE 301  
CULPEPER, VA 22701  
540-829-8260

*Approved*  
*Town Council – February 13, 2018*

# FACILITIES STANDARDS MANUAL

---

## CHAPTER 1 - IN GENERAL

1.100	AUTHORITY.....	4
1.200	INTERPRETATION AND REVISION.....	4
1.300	REFERENCE MATERIAL.....	5

## CHAPTER 2 - WATER AND SANITARY SEWER SYSTEMS

2.100	GENERALLY.....	8
2.110	PUBLIC WATER.....	8
2.120	PUBLIC SANITARY SEWER FACILITIES.....	8
2.130	PRIVATE WATER AND SANITARY SEWERS.....	9
2.140	WATER METERS.....	9
2.200	FIRE PROTECTION.....	9
2.300	PLAN REQUIREMENTS.....	11
2.400	DEDICATION OF WATER MAINS AND SANITARY SEWERS.....	11
2.410	WATER AND SANITARY SEWER EASEMENTS.....	12
2.500	LOCATION OF WATERMAINS IN REGARD TO PUBLIC RIGHT-OF-WAY.....	12
2.600	CROSS-CONNECTION AND BACKFLOW PROTECTION.....	13
2.610	INSTALLATION AND MAINTENANCE OF BACKFLOW PREVENTION DEVICES.....	14
2.700	SANITARY SEWER CONNECTIONS.....	14
2.710	SANITARY SEWER LATERALS.....	14
2.720	SANITARY SEWER PUMPING STATIONS.....	15
2.730	ABRASIVE WASTE INTERCEPTORS.....	22
2.740	GRINDER PUMPS.....	22

## CHAPTER 3 - TRANSPORTATION

3.100	GENERALLY.....	23
3.110	DEFINITIONS.....	23
3.200	TRANSPORTATION PLANNING.....	24
3.300	DESIGN AND CONSTRUCTION STANDARDS.....	27
3.310	STREET DESIGN REQUIREMENTS.....	27
3.320	PUBLIC ROADWAY STANDARDS.....	31
3.330	PRIVATE STREETS AND ACCESSWAYS.....	32
3.340	PAVEMENT THICKNESS DESIGN STANDARDS.....	33
3.400	PARKING STANDARDS.....	36
3.500	PEDESTRIAN SIDEWALKS AND TRAILS.....	40
3.600	STREET NAMES AND NUMBERS.....	43
3.700	MAIL BOX REQUIREMENTS.....	44
3.800	TEMPORARY STREET NAME SIGNS & POSTING OF ADDRESS.....	44

## CHAPTER 4 - RESERVED

## CHAPTER 5 - MISCELLANEOUS DESIGN STANDARDS

5.100	LANDSCAPE PLANS.....	45
5.200	EROSION AND SEDIMENT CONTROL.....	50
5.300	FIRE LANE SIGNS.....	51
5.310	STREET NAME SIGNS & POSTS.....	51
5.320	HANDICAP SIGNS.....	51

# FACILITIES STANDARDS MANUAL

---

5.400	MONUMENTS.....	51
5.500	INDIVIDUAL LOT-GRADING PLANS.....	52
5.600	CERTIFICATE OF OCCUPANCY PREREQUISITES IN SUBDIVISIONS.....	52
5.700	SUBDIVISION CONSTRUCTION ORDER.....	53
5.800	INSPECTION REQUIREMENTS.....	54
5.900	PLACEMENT OF DUMPSTERS.....	54
5.910	SAFETY FENCING REQUIRED.....	55

## CHAPTER 6 - ELECTRICAL AND LIGHTING

6.100	GENERALLY.....	56
6.200	LOCATION OF TOWN EQUIPMENT.....	57
6.300	ELECTRIC METERS.....	57
6.400	PLAN REQUIREMENTS.....	58
6.500	ELECTRIC UTILITY EASEMENTS.....	58
6.600	CHARACTERISTICS OF ELECTRICITY SUPPLIED.....	58
6.700	STREET AND SITE LIGHTING STANDARDS.....	59
6.710	GENERAL REQUIREMENTS.....	59
6.720	LIGHTING STANDARDS.....	59

## CHAPTER 7 - REFUSE COLLECTION

7.100	GENERALLY.....	61
7.200	RESIDENTIAL.....	61
7.300	COMMERCIAL AND INDUSTRIAL.....	61
7.400	SCREENING OR REFUSE & RECYCLING CONTAINERS.....	61

## CHAPTER 8 - REAR LOADING CONTAINERS

8.100	SCOPE OF CHAPTER.....	62
8.200	SPECIFICATIONS; PURCHASE; MAINTENANCE.....	62
8.300	LOCATION.....	62
8.400	CONCRETE PLATFORMS.....	62

## DIAGRAMS

3.1	INTERSECTION SPACING.....	64
3.2	ENTRANCE SPACING.....	64
3.3	CURB AND GUTTER SIDEWALK.....	65
3.3.1	STREETS & SIDEWALK SECTIONS.....	66
3.4	INTERSECTION LANDING.....	67
3.5	CUL-DE-SAC DITCH SECTION.....	68
3.6	STANDARD DRIVEWAY ENTRANCE.....	69
3.7	COMMERCIAL ENTRANCES.....	70
3.7.1	NO PARKING SIGN DETAIL.....	71
3.8	ENTRANCE SITE DISTANCE.....	72
3.9	ACCELERATION AND DECELERATION LANES.....	73
5.1	STREET NAME SIGN.....	74
5.1 a	SIGN INSTALLATION DIRECT MOUNT METHOD.....	75
5.2	SQUARE TUBE SIGN POST.....	76

# FACILITIES STANDARDS MANUAL

---

## DIAGRAMS - continued

5.3	ACCESSIBLE SIGNAGE.....	77
5.4	CROSSWALK OVERLAY BOUNDARY.....	78
5.5	DEVELOPMENT DESIGN EXAMPLES.....	79
5.6	BICYCLE PARKING RACK.....	80
5.7	PEDESTRIAN CROSSWALKS.....	81
5.8	EARTH BERM.....	82
6.0-6.3	LIGHTING SPECIFICATIONS.....	83-88
6.6	METER BASE INSTALLATION.....	89
6.7	METER BASE INSTALLATION STICKER.....	90
6.8	TYPICAL STREET TREE PLANTING.....	91

# FACILITIES STANDARDS MANUAL

---

## CHAPTER 1. IN GENERAL

### Sec. 1.100. Authority.

This document, entitled the Town of Culpeper Facilities Standards Manual, has been developed and designed to assist the public and the development community in determining the policies which apply to land development in the Town. It contains information primarily concerned with the design and construction standards and guidelines for improvements related to subdivisions and site plans.

By resolution at its meeting on April 13, 1999, the Culpeper Town Council adopted this Manual to become effective May 1, 1999, and incorporated by reference in the Subdivision Ordinance of the Town of Culpeper. The following implementation procedure shall be followed for this version of the Manual:

a. All development projects which were granted an approved preliminary subdivision or preliminary site plan prior to the adoption of this Manual will be accepted and reviewed by the Town of Culpeper in accordance with the development standards and ordinances in effect at the time of the said application approval.

b. Applications not meeting the aforementioned criteria shall be designed and submitted in accordance with the latest version of the Manual.

### Sec. 1.200. Interpretation, revisions, and appeals.

a. Interpretation: These standards and guidelines are designed to supplement the provisions of existing Federal and State regulations and the Code of the Town of Culpeper and its ordinances. Nothing herein shall be deemed to waive or modify other requirements of existing Town Codes. Except as expressly provided otherwise in this document, the Director of Planning & Community Development, here after referred to as the "Director" is the designated official charged with the administration of the standards and requirements contained in this Manual.

b. Revision: As new basic information on design criteria becomes available and is accepted and as Federal, State, and Town laws, regulations, and standards are changed, they will be reflected in this publication after at least an annual review. Any record plats, final site plans or construction plans and profiles submitted prior to the approval of any revisions will comply with the standards in effect at the time of the officially accepted submission for such record plats, final site plans, and/or construction plans and profiles.

The Technical Review Committee shall meet at least once a year to review the Facilities Standards Manual. As appropriate, the Director may convene a staff meeting to consider revisions to the Facilities Standards Manual. A courtesy copy of all proposed revisions will be mailed to all interested parties as determined by the Director. All Facilities Standards Manual revisions shall be approved by Town Council following recommendations from the Planning Commission and after a Planning Commission public hearing.

c. Appeals: Any applicant who is aggrieved by an interpretation or decision made by the Director in the administration of the standards and requirements contained in this manual may, within five (5) working days of receiving written notice of such decision or interpretation, deliver a written notice of appeal to the Town Manager requesting the Town Manager to appoint a committee to review the matter. Such committee shall consist of at least three members of the Technical Review Committee. The committee shall consider the appeal at a time and place convenient to the applicant and Town Manager, but in no event

# FACILITIES STANDARDS MANUAL

---

more than thirty (30) days after the appeal request is delivered. The Committee shall make a written recommendation to the Town Manager stating the basis for such recommendation. Within ten (10) days of receiving the Committee recommendations, the Town Manager shall make a decision regarding the appeal.

The applicant may appeal the Town Manager's decision to the Town Council by giving written notice of appeal to the Mayor within five (5) working days of receiving written notice of such decision. If the applicant is aggrieved by the Town Council decision, the applicant may take such action as is otherwise provided by law with respect to the subject land use application at the appropriate time.

Any applicant who files an appeal under this subsection of the Facilities Standards Manual shall waive, during the period of pendency of the appeal, any right to require the Town of Culpeper to take any action to approve or disapprove the application pursuant to any statutory or other legally imposed timeline requirement. Any applicant giving notice of such appeal shall execute and deliver to the said Town Manager such written waiver along with such notification in substantially the following language:

"I/we hereby waive any right I/we may have to require the Town of Culpeper to take any action to approve or disapprove the subject application during the pendency of the appeal, such that the time which elapses from the date of delivery of this notification to the Town Manager until the date of the final decision on this appeal by the Town Manager (or Town Council, if appealed to that level) shall not be counted in determining the date as of which Town of Culpeper action on the application is legally required."

If the Planning Commission has however approved, conditionally approved, or denied a site plan or other submittal to which the staff determination or interpretation applies, no appeal is available to the Town Manager or Town Council, but shall be taken as otherwise provided by state law.

d. Disclaimer of Liability, waivers: The purpose of this manual is to establish reasonable land development standards and guidelines for the protection and promotion of the general health, safety, and welfare of the Town of Culpeper's residents. Approval of plans and plats by the Town of Culpeper or its agencies pursuant to this Manual is not intended and shall not be deemed as a guarantee or warranty for any individual, landowner, or developer that any improvements will be designed, planned, constructed, or operated in any particular manner or be free from defects. Such approval shall create no duty or result in any liability on the part of the Town of Culpeper, its officials, or employees for any claim, demand, suit, or damages alleged to have resulted from the development, construction, existence, or operation of improvements constructed pursuant to such approved plans or plats. Further, no such approval shall operate as or be deemed as a waiver of any provision or requirement of Town ordinances or this manual unless such waiver has been specifically granted in writing by the Town Manager as a variation allowed under Section 1.200(a) hereof. In the event that any aspect of any such approved plan or plat fails to comply with any provision or requirement of this Manual or other Federal, State or local requirements in effect at the time of such approval, such provision or requirement of this manual and all other applicable requirements shall take precedence over the approved plans, and development shall be in accordance with such requirements and this manual.

## **Sec. 1.300. Reference material.**

In order to properly utilize this Manual, the designer or user in general should have certain publications readily available, as they are referenced throughout this document.

A listing of the most commonly utilized publications is as follows:

# FACILITIES STANDARDS MANUAL

---

- \* Town of Culpeper Cross Connection Control Manual
- \* “The Sewage Handling and Disposal Regulations,” Board of Health, Commonwealth of Virginia
- \* “Virginia Water Works Regulations,” State Health Department, Division of Water Engineering
- \* “Virginia Erosion and Sediment Control Handbook”
- \* The Town of Culpeper Rules and Regulations Water and Sanitary Sewer Construction Specifications and Standards
- \* “Appendix D Fire Apparatus Access Roads 2012 International Fire Code”, latest edition
- \* “Soils Map of Culpeper County,” Department of Agriculture, Soil Conservation Service
- \* Controlling Urban Runoff: A Practical Manual for Planning and Designing Urban BMPs
- \* Federal Manual for Identifying and Delineating Jurisdictional Wetlands. Additional reference materials specific to each subject area is listed at the end of each chapter
- \* “Guide for Determination of Required Fire Flow,” Insurance Services Office, 160 Water Street, New York, NY 10038
- \* “Grading Schedule for Municipal Fire Protection,” Insurance Services Office, 160 Water Street, New York, NY 10038
- \* “The Code of the Town of Culpeper”
- \* “AWWA Standards.” American Water Works Association
- \* “NFPA Standards,” National Fire Protection Association
- \* VDOT Drainage Manual, Location and Design Division
- \* ITE Trip Generation, Information Report of the Institute of Transportation Engineers
- \* Highway Capacity Manual, Transportation Research Board
- \* VDOT Minimum Standards of Entrances to State Highways, Traffic Engineering Division
- \* VDOT Land Use Permit Manual, Maintenance Division
- \* VDOT Road and Bridge Specifications, Construction Division
- \* AASHTO, A Policy and Geometric Design of Highways and Streets
- \* AASHTO, Standard Specifications for Highway Bridges
- \* VDOT Modifications to Standard Specifications for Highway Bridges, Bridge and Structure Division

# FACILITIES STANDARDS MANUAL

---

- \* Manual on Uniform Traffic Control Devices for Streets and Highways (MUTCD), Federal Highway Administration (USDOT)
- \* VDOT Virginia Supplement to the Manual on Uniform Traffic Control Devices, Traffic Engineering Division
- \* Design Guide for Subdivision Road Pavements in Virginia, N. K. Vaswani, Transportation Research Center.
- \* Recommended Design Method for Flexible Pavements in Virginia, N. K. Vaswani, Transportation Research Center.
- \* Virginia Uniform Statewide Building Code
- \* American National Standards Institute (ANSI)
- \* VDOT Subdivision Street Requirements, Secondary Roads Division
- \* VDOT Road Design Manual, Location and Design Division
- \* Americans with Disabilities Act (ADA)
- \* Fair Housing Act
- \* National Electrical Code, Rural Electrical Authority: Specifications for Construction Manual
- \* U. S. Department of Agriculture, Soil Conservation Service, National Engineering Handbook, Section 4, Hydrology
- \* VDOT Guidelines for the installation of marked crosswalks



# FACILITIES STANDARDS MANUAL

---

## CHAPTER 2. WATER AND SANITARY SEWER SYSTEMS

### Sec. 2.100. Generally.

a. Applicable Design Standards: Applicants are reminded that, in all cases, the applicable requirements of the Virginia Department of Health "Waterworks Regulations" and "Sewage Collection and Treatment Regulations" other state and Town of Culpeper Code and/or construction standards, where applicable, must be met. Applications proposing water systems serving fifteen (15) or more water connections or where fire flow is required, or applications proposing sanitary sewer systems serving populations of four hundred (400) or more must submit plans and specifications to the Virginia Department of Health for review and approval. All other applications are subject to review and approval of the Town of Culpeper. The applicant is referred to the codified ordinances of the Town of Culpeper Code, Chapter 4, Article II Building Permits for permitting requirements.

b. Water Connections Required: Provided public water is within two hundred fifty (250) feet of the principle structure, the owner of all houses, buildings, or properties used for human occupancy, employment, recreation or other purposes, situated within the Town of Culpeper and abutting on any street, alley, or right-of-way in which there is now located or may be located in the future a public water main of the Town, is hereby required at his expense to install suitable water facilities therein, and to connect such facilities directly to the proper public water main when it involves new construction, failed well, or by requirement of the Health Department and in accordance with the provisions of this manual, within ninety (90) days after date of official notice to do so.

c. Sanitary Sewer Connections Required: Provided public sanitary sewer is within two hundred fifty (250) feet of the principle structure, the owner of all houses, buildings, or properties used for human occupancy, employment, recreation or other purposes, situated within the Town of Culpeper and abutting on any street, alley, or right-of-way in which there is now located or may in the future be located a public sanitary sewer or combined sewer of the Town of Culpeper, is hereby required at his expense to install suitable toilet facilities therein, and to connect such facilities directly to the proper public sanitary sewer main when it involves new construction, failed septic system, or by requirement of the health department and in accordance with the provisions of this manual, within ninety (90) days after date of official notice to do so.

### Sec. 2.110. Public water.

Where Town of Culpeper public water is available, such service shall be extended, at property owner expense, to each lot within a subdivision. The Town of Culpeper water supply is considered available if a water line of adequate size (or at which point a water line has been proposed to be constructed by the Town of Culpeper within a period of twelve (12) months of the initial date of application for recordation of the subdivider's plat) is located within one thousand (1,000) feet from the proposed subdivision provided adequate treatment and storage capacity exists to supply the volume of water required by the proposed subdivision.

### Sec. 2.120. Public sanitary sewer facilities.

Where Town of Culpeper public sanitary sewer facilities are available, such service shall be extended, at property owner expense, to each lot within a subdivision. The Town of Culpeper sanitary sewer facilities are considered available if a sewer line of adequate size (or at which point a sewer line has been proposed to be constructed by the Town of Culpeper within a period of twelve (12) months of the initial date of application for recordation of the subdivider's plat) is located within one thousand (1,000) feet [304.8m]

---

# FACILITIES STANDARDS MANUAL

---

from the proposed subdivision, provided adequate treatment capacity exists to treat the volume of wastewater to be discharged by the proposed subdivision.

## **Sec. 2.130. Private water and sanitary sewers.**

Nothing in this manual shall prevent the installation of privately owned water or sewerage facilities or both in areas where public water or sewerage facilities or both are not available; provided that such installations shall meet all State requirements and Town of Culpeper regulations applicable to such installation. Specifications of all private water or sewerage systems serving more than one (1) dwelling unit shall be as those standards established for public water or sewer systems.

Where a public or combined sewer is not available under the provisions of the Section 2.100(c), the building sewer shall be connected to a private sewage disposal system complying with the Culpeper Town Code.

The type, capacities, location and layout of a private sewage disposal system shall comply with all recommendations of the State Department of Health. No septic tank or cesspool shall be permitted to discharge to any natural outlet.

## **Sec. 2.140. Water meters.**

A meter box shall be placed at the cost of the Town of Culpeper on each service pipe supplied with water from the mains of the Town of Culpeper's waterworks to any building or premises. Any increase in size or additional meters shall be at the expense of the developer.

Each water meter is the property of the Town of Culpeper and at all times subject to its control and inspection. Where any meter is located on any private property, building or premises, the Town of Culpeper shall have the right to enter the same at all reasonable hours for the purpose of examining, repairing, replacing or removing such meter or to take meter readings.

Where practical, water meters shall be placed at or near the property line. A utility easement shall be provided if the water meter is not located on the property line.

The property owner shall pay all costs of running a line from the Town of Culpeper water main to the property line. The work shall be done by the Town of Culpeper, and the cost thereof paid by the property owner(s). The costs of the connection shall be set by the Town of Culpeper.

## **Sec. 2.200. Fire protection.**

a. Rates of flow for fire protection shall be estimated based on the 1980 ISO Fire Suppression Rating Schedule, Section 1, Public Fire Suppression, Subsection 300, Needed Fire Flow, including definitions extracted from the CFRS and including occupancy classifications, non-manufacturing and occupancy classifications manufacturing and special hazards. A maximum allowance of fifty percent (50%) reduction in needed fire flow may be allowed for buildings with automatic sprinkler systems that provide full protection. Calculations and other information determining both the water supply required and the water supply available for fire protection shall be provided on applicable applications.

b. The minimum fire flow from any individual fire hydrant shall be 500 gpm. The minimum flowing pressure at maximum flow shall be 20 psi.

# FACILITIES STANDARDS MANUAL

---

c. During maximum rated fire flow conditions, the pressure drop in any fire protection system shall not exceed 15 psi from the point of connection at the existing town system to any fire hydrant or any combination of required hydrants.

d. The minimum size water line used for fire protection to properties zoned single family residential shall be six (6) inches in size. The minimum size water line used for fire protection to properties zoned multifamily residential, commercial, or industrial shall be eight (8) inches in size.

e. Dead end lines shall not contain more than 600 feet of the minimum sized line. Additional lengths required shall be provided by increasing the line size.

f. Fire hydrants shall be required for all subdivisions, except those coming under the private water provision of Code Section 22-20. Fire hydrants shall be located no more than one thousand (1,000) feet apart and within fire hundred (500) feet of any structure, as measured along the roadway, and shall be approved by the applicable approving authority. To eliminate future street openings, all underground utilities for fire hydrants themselves and all other supply improvements, shall be installed before any final paving of a street shown on the subdivision plat.

g. Fire hydrant spacing for properties zoned multi-family residential, commercial, or industrial shall not exceed five hundred (500) feet or require a hose lay of over three hundred fifty (350) feet from the hydrant to any part of any structure to be protected. Where multiple fire hydrants are needed to supply the required fire flow, all necessary hydrants must be located within the specified hose lay.

h. Structures protected by an automatic sprinkler system and directly connected to the Town's water system require installation of an approved backflow device as required by the town's Backflow and Cross Connection program.

i. The property owner shall be responsible for properly maintaining the fire sprinkler system. The owner shall provide access to all components of the system that require inspection, testing or maintenance.

j. It shall be unlawful for any person to flush, test, or shut down a fire sprinkler system without written permission from the town manager. The permit shall include the purpose of the test, flushing or shut down, the system component involved, and the estimated time.

k. Any flushing of fire sprinkler systems shall be scheduled with the director of public works to result in a minimum of interference in water service throughout the existing system. No more than four (4) flushings or testings will be permitted in any given year.

l. A town representative shall be present during any fire sprinkler system flushing or testing. Water used during flushing or testing will be measured using the best available method and paid for by the owner at the current water rate. A permit fee as established by Council will also be required.

## **Sec. 2.210. Acceptance Testing for Fire Protection Lines:**

a. Acceptance testing shall be required on all fire protection lines prior to concealment and use. Fire protection lines shall be hydrostatically tested at not less than 200 pounds per square inch (psi) (1,378.952 kilopascals) for two (2) hours.

# FACILITIES STANDARDS MANUAL

b. Concealment of an underground fire protection line prior to the acceptance testing may occur if a visual inspection of the system is conducted to verify that piping and anchorage is installed in an approved manner, and if the developer or contractor assumes responsibility for corrections to failures of the hydrostatic test.

WATER FLOW RATE FOR LINE FLUSHING								
Pipe Size			Flush Orifice Size			Flow Rate		
inches	/	mm	inches	/	mm	gpm	/	lps
2	/	50	2	/	50	60	/	3.785
4	/	100	3	/	80	400	/	22.236
6	/	150	4	/	100	750	/	47.318
8	/	200	4	/	100	1,000	/	63.090
10	/	250	6	/	150	1,500	/	94.635
12	/	300	6	/	150	2,000	/	126.618

c. Flushing of a fire protection line shall occur prior to admittance of any water through the line and into the fire protection system. The minimum water flow required for line flushing shall comply with the table below or the hydrostatically calculated water demand rate of the system, whichever is greater.

d. Hydrostatic testing of the fire protection line shall consist of testing the line from the valve at the water main up to, and including, the temporary flange/gate valve assembly.

**Sec. 2.220. Fire Lines:**

a. Fire protection lines shall be a separate connection to the water main unless otherwise directed by the Town of Culpeper.

b. Fire protection lines shall have a valve at its connection to the main.

c. All water lines serving a fire suppression system in a building shall be shown on the project plans. All fire lines shall be owned and maintained by the property owner. A valve shall be located on the fire line at the point it connects to the public water system.

**Sec. 2.300. Plan requirements.**

All subdividers and developers shall submit twelve (12) copies of plans for proposed water and sanitary sewer to the Town of Culpeper Planning Department before installing any lines. No water or sanitary sewer lines shall be connected to the Town of Culpeper water or sewer system without first being approved by the Town Manager.

**Sec. 2.400. Dedication of water mains and sanitary sewers.**

Before any service taps are made to any existing water mains or sanitary sewers or any future taps made, the mains and/or sewers shall be deeded to and accepted by the Town of Culpeper so that they can receive the proper maintenance.

All subdividers, before any water or sewer construction is made, shall furnish the Town of Culpeper rights-of-way for the same, free of charge.

# FACILITIES STANDARDS MANUAL

---

## Sec. 2.410. Water and sanitary sewer easements.

a. Utility maintenance easements: Utility easements shall be a minimum of twenty (20) feet for sanitary sewer and a minimum of ten (10) feet for water. Easement widths may be reduced when utilities are parallel.

b. Where deemed necessary by the Director, and in order to ensure maximum utilization of public water and sanitary sewer systems, it shall be required that appropriate utility easements be provided to adjacent properties for access to said public utilities.

## Sec. 2.500. Location of watermains in regard to public right-of-way.

a. Water mains shall be allowed within the public right-of-way.

b. Divided Roads: It is the general intent that water mains will not be allowed under the pavement of divided roads having four or more lanes. However, water mains within the right-of-way of such roads may be permitted subject to the Town of Culpeper's approval. The conditions listed in items 1 through 4 below shall be present to allow placement of the water main under the pavement of such roads. When water mains are permitted within the pavement of divided roadways, they are to be located five (5) feet from the outside edge of the pavement or seven (7) feet from the face of curb. It should be noted that for the conditions and situations cited below, the Town of Culpeper may determine that there are compelling design or safety issues which shall demand consideration of an alternate location. In instances that require special consideration, applicants are encouraged to seek Town of Culpeper concurrence of the waterline design concept prior to or during the preliminary plan process.

1. When the divided roadway is designed for aesthetic purposes rather than to meet projected traffic volumes.
2. In areas where an existing and sufficient interparcel access is available to provide an alternative route for traffic, as required for water main maintenance.
3. Existing water lines are located under existing pavement.
4. The extension of water lines under undivided roadways through intersections widened, only through the intersection, to a divided section.

c. Undivided Roads:

1. Water mains will be allowed under the pavement for all undivided roadways unless compelling design or safety issues are identified by the Town of Culpeper. When permitted, these water mains shall generally be placed within the pavement, no less than five (5) feet from the outside edge of the gutter pan or seven (7) feet from the face of curb.
2. Sanitary sewer mains shall be placed under pavement for all undivided roadways. Sanitary sewer mains may be constructed on private property if it is the only feasible way to serve isolated properties, low lots, or make connection to another sanitary sewer, on the condition that a duly recorded easement exists.

# FACILITIES STANDARDS MANUAL

---

## Sec. 2.600. Cross-connection and backflow protection.

a. An approved backflow prevention device shall be installed on each service line to a consumer's water system where, in the judgment of the Town of Culpeper, a health, pollution or system hazard to the water system exists.

b. An approved backflow prevention device shall be installed on each service line to a consumer's water system serving premises where the following conditions exist, except as noted in 7 below:

1. Premises having an auxiliary water system, unless such auxiliary water system is accepted as an additional source by the Town of Culpeper.
2. Premises on which any substance is handled in a manner as to create actual or potential hazard to the water system (including premises having sources or systems containing process fluids or waters from a waterworks which are not under the control of the Town of Culpeper).
3. Premises having internal cross-connection that, in the judgment of the authorized Town representative may not be easily correctable or intricate plumbing arrangements which make it impractical to determine whether or not cross-connections exist.
4. Premises where, because of security requirements or other prohibitions or restrictions, it is impossible or impractical to make a complete cross-connection survey.
5. Premises having a repeated history of cross-connection being established or reestablished.
6. Premises having fire protection systems utilizing combinations of sprinklers, fire loops, storage tanks, pumps, antifreeze protection or auxiliary water.
7. Premises having booster pump(s) connected to the waterworks shall be equipped with a low-pressure cutoff device to shut off the booster pump(s) when the pressure in the waterworks drops to a minimum of ten (10) PSI [68.9 kPa] gauge.
8. Other premises specified by the Town of Culpeper when cause can be shown that a potential cross-connection hazard exists.

c. An approved backflow prevention device shall be installed on each service line to a consumer's water system serving the following types of facilities.

1. Hospitals, mortuaries, clinics, nursing homes;
2. Laboratories;
3. Piers, docks, waterfront facilities;
4. Sewage treatment plants, sewage pumping stations or stormwater pumping stations;

# FACILITIES STANDARDS MANUAL

---

5. Food and beverage processing plants;
6. Chemical plants, dyeing plants;
7. Metal plating industries;
8. Petroleum processing or storage plants;
9. Radioactive materials processing plants, nuclear reactors;
10. Car washes;
11. Lawn sprinklers systems, irrigation systems;
12. Fire service systems;
13. Slaughterhouses and poultry processing plants;
14. Farms where water is used for other than household purposes;
15. Others specified by the authorized Town representative where potential backflow or cross-connection hazard can be shown.

## **Sec. 2.610. Installation and maintenance of backflow prevention devices.**

Approval of backflow prevention devices and the type of protection required shall be in accordance with the requirements and standards provided in Part II, Section 12 VAC-5-590-580 through Section 12 VAC5-590-630 of the Virginia Department of Health Waterworks Regulations.

## **Sec. 2.700. Sanitary sewer connections.**

The property owner shall pay all costs of running a line from the Town of Culpeper sewer line to the property line. The work shall be done by the Town of Culpeper, and the cost thereof paid by the property owner(s). The costs of connection shall be set by the Town Council.

All house sewers connecting with a main sewer shall be constructed in accordance with the facts stated in the application for a sewer connection permit and in conformance with the plumbing code of the Town of Culpeper.

## **Sec. 2.710. Sanitary sewer laterals.**

a. A separate and independent building sewer shall be provided for every building, except that where one (1) building stands at the rear of another on an interior lot, and no private sewer is available or can be constructed to the rear building through an adjoining alley, court, yard or driveway, the building sewer from the front building may be extended to the rear building, provided such extension is subject to the payment of additional tap fees.

## **FACILITIES STANDARDS MANUAL**

---

b. Old building sewers may be used in connection with new buildings only when they are found, on examination and test by the authorized Town representative, to meet all requirements of this division.

c. The size, slope, alignment, materials of construction of a building sewer, and the methods to be used in excavation, placing of the pipe, jointing, testing, and backfilling the trench, shall all conform to the requirements of the building and plumbing codes or other applicable rules and regulations of the Town of Culpeper.

d. Whenever possible, the building sewer shall be brought to the building at an elevation below the basement floor. In all buildings in which any building drain is too low to permit gravity flow to the public sewer, sanitary sewage carried by such building drain shall be lifted by an approved means and discharged to the building sewer.

e. No person shall make connection of roof downspouts, exterior foundation drains, areaway drains or other sources of surface runoff or groundwater to a building sewer or building drain which in turn is connected directly or indirectly to a public sanitary sewer.

f. The connection of the building sewer into the public sewer shall conform to the requirements of the building and plumbing codes or other applicable rules and regulations of the Town of Culpeper. All such connections shall be made gas tight and water tight. Any deviation from the prescribed procedures and materials must be approved before installation.

### **Sec. 2.720. Sanitary sewer pumping stations.**

a. Consideration for allowing the construction of new sanitary sewer pumping stations to serve new development shall only be made by the Town after all options to serve the development by gravity sanitary sewer mains have been exhausted by the developer to the Town's satisfaction, and the only possible option for such service is through the construction of a sanitary sewer pumping station.

b. Whenever it is determined that no option other than constructing a sanitary sewer pumping station exists, the developer shall be responsible for designing the pumping station in accordance with the requirements of the Town. The developer shall submit plans and specifications for the pumping station to the Town and the Virginia Department of Health (VDH), and shall be responsible for any modifications to the plans and specifications as required by either the Town or VDH. The developer shall obtain a Certificate to Construct (CTC) from the Department of Environmental Quality (DEQ) prior to any construction activities. A copy of the CTC shall be provided to the Town. During construction, the Town shall conduct inspections of the project to ensure compliance with the approved plans and specifications. Upon completion of construction, the developer shall be responsible for scheduling final inspection of the project with the VDH, and shall notify the Town of the time of such inspection. Upon approval from the VDH to operate the pumping station, a Certificate to Operate (CTO), issued by the VDH in the name of the Town of Culpeper, shall be delivered to the Town.

c. Upon the issuance of a CTO by the VDH, the developer shall deed the pump station and the property on which it is located to the Town of Culpeper. Such deed shall include all necessary ingress/egress easements, and shall be at no cost to the Town. At such time the deed is properly recorded, the Town will accept the pumping station and will be responsible for its operation.



# FACILITIES STANDARDS MANUAL

---

d. There shall be no cost to the Town with regard to design, construction, permitting or any other expenses related to the delivery of the fully constructed and operational pumping station. The developer shall solely bare such costs up to and including deeding of the pump station (with all necessary easements) to the Town.

e. Sanitary Sewer Pumping Station—In General

1. Site Requirements

- a. Pumping station sites are to be located so as to be accessible by Town vehicles at all times. The minimum site size shall be one hundred (100) feet wide by one hundred (100) feet long.
- b. Pumping station sites are to be fenced by a six (6) foot high chain link fence, topped with three (3) strands of barbed wire. The fenced area of the site shall be at least seventy (70) feet by seventy (70) feet and shall be located in the center of the entire site. The fence shall have a double swing sixteen (16) foot wide gate that is lockable.
- c. Visual screening shall be provided between the fence and property line. Such screening shall consist of one (1) row of evergreen trees planted ten (10) feet on center, and shall be a minimum distance of ten (10) feet from the fence. Such screening shall have a one (1) year warranty by the developer.
- d. An all weather access road shall be provided for ingress and egress before conveyance of facility to the Town. The road shall be a minimum of fifteen (15) feet in width.

2. Pumping Station Requirements

- a. The pumping station wet well shall be either cast-in-place concrete or pre-cast concrete, and shall meet or exceed the minimum requirements of the VDH. Access to the wet well shall be provided by a thirty(30) inch by thirty(30) inch aluminum hatch that is lockable. A stainless steel bar shall be provided inside the wet well for float switch control mounting. This bar shall be mounted to the inside top of the wet well using stainless steel hardware. The interior floor of the wet well shall be sloped at an adequate grade to ensure all solids can be pumped from the wet well. The wet well shall include a ductile iron screened vent pipe.
- b. The pumping station building shall be either frame construction, with a full brick exterior and a pitched roof, or an aggregate pre-manufactured building approved by the Town. The Town shall determine the minimum acceptable dimensions of the building upon submittal of the draft plans and specifications. The floor of the building shall be concrete. The building shall have double swing metal doors with a minimum opening of six (6) feet. The doors shall be located so as to be in line with the gated opening in the fence. The doors shall have a commercial grade lockset and shall be keyed as required by the Town. The Town shall be provided with six (6) lockset keys. The pumping station building shall be located on the site in such a way as to be partially over the wet

## FACILITIES STANDARDS MANUAL

---

well, thereby providing suction line access to the wet well through the floor of the station. The floor penetrations to the wet well shall be sealed so as not to allow any gases from the wet well to enter the pumping station building.

- c. Ventilation of the pumping station building shall be provided by the installation of an exhaust fan. The exhaust fan shall be wall-mounted and located on the opposite wall from a through-wall louvered intake. The exhaust fan shall be controlled by a switch that activates the exhaust fan upon opening of the exterior building door, as well as a wall switch that overrides the door switch when extended occupancy of the pumping station building by personnel is required.
- d. All electrical installation shall comply with all national, state and local building codes. The developer shall contract with the electric utility provider for service, and shall be responsible for any fees associated with providing power to the pumping station. Upon the issuance of an occupancy permit, and conveyance by deed, the electric service shall be placed in the name of the Town of Culpeper. The developer shall obtain and install the appropriate meter base for the pumping station. A minimum of two (2) GFIC duplex outlets shall be provided inside the pumping station building. All wiring from the main service panel to its termination point shall be in conduit. Separate heavy-duty six hundred (600) volt disconnect switches shall be provided to each pump motor.
- e. A six hundred (600) volt manual transfer switch of adequate amperage rating shall be provided. The transfer switch shall have a manual throw switch handle capable of being locked in either the normal or standby power position, shall be mounted on the interior wall of the pumping station building, and shall be rated NEMA 3R. A conduit shall be installed from the manual transfer switch to the outside of the building. An Appleton receptacle (#AJA20034200) shall be connected to the conduit at the outside of the building, and shall be housed in a NEMA 3R enclosure.
- f. The pumping station building shall be electrically heated so as to maintain a minimum temperature of 68 degrees F in the winter. The heater shall be controlled with an adjustable thermostat.
- g. Interior lighting shall be provided through two (2) ceiling-mounted light fixtures, each fixture containing two (2) four (4) feet long fluorescent tubes.
- h. Exterior lighting shall be provided as follows: One (1) sodium vapor light fixture mounted on the wall adjacent to one (1) side of the exterior door. This fixture shall be controlled by a photocell. One (1) sodium vapor light mounted on the exterior wall on which the Appleton receptacle is mounted. This fixture shall be controlled by a switch located inside the pumping station building. One (1) sodium vapor light on the exterior wall that faces the wet well. This fixture shall be controlled by a switch located inside the pumping station building.
- i. The pumping station shall be new, manufactured by Smith & Loveless, Inc., and shall be the standard wet well mounted suction lift pump station (2 pumps). The pumping station shall be constructed in one (1) complete factory-built assembly.

# FACILITIES STANDARDS MANUAL

---

## j. Sewage Pumps

1. The pumps shall be four (4) inch vertical, recessed impeller type, with the impeller mounted completely out of the flow path between the pump inlet and discharge connection so that solids pumped are not to flow through the impeller. All internal clearances shall be equal to the discharge diameter so that all material that enters the discharge will pass through the pump. Pumping stations requiring pumps larger than four (4) inches shall be evaluated and approved by the Town on an individual basis.
2. The pumps shall be of heavy cast iron construction, especially designed for the use of mechanical seals and vacuum priming. In order to minimize seal wear caused by lineal movement of the shaft, the shaft bearing nearest the pump impeller shall be locked in place so that end-play is limited to the clearance within the bearing. To minimize seal wear resulting from shaft deflection caused by the radial thrust of the pumps, the shaft from the top of the impeller to the lower bearing supporting the impeller shall have a minimum diameter of 2 1/8". The dimension from the lower bearing to the top of the impeller hub shall not exceed six (6) inches.
3. The bearing nearest the impeller shall be designed for the combined thrust and radial load. The upper bearing shall be free to move lineally with the thermal expansion of the shaft and shall carry only radial loads.
4. The shaft shall be solid stainless steel through the pump and bottom bearing to eliminate corrosion within the pump or the mechanical seal. Removable shaft sleeves will not be acceptable if the shaft under the sleeve does not meet the specified minimum diameter.
5. The pump impeller shall produce a turbine-like flow pattern within the casing, generating flow. It shall be made of close-graded cast iron and shall be balanced. The impeller shall be keyed with a stainless steel key and secured to the motor shaft by a stainless steel cap screw equipped with a Nylock or other suitable self-locking device. The impeller shall not be screwed or pinned to the motor pump shaft and shall be readily removable without the use of special tools. To prevent the build-up of stringy materials, grit and other foreign particles around the pump shaft, all impellers less than full diameter shall be trimmed with the back shroud remaining full diameter so that close minimum clearance from shroud to casing is maintained. Both the end of the shaft and the bore of the impeller shall be tapered to permit easy removal of the impeller from the shaft.
6. The pump shall be constructed so as to permit priming from the low-pressure area behind the impeller. Priming from the high-pressure connections, tending to cause solids to enter and clog the priming system, will not be acceptable. The priming bowl shall be transparent to enable the operator to monitor the priming level.
7. The pump shall be arranged so that the complete rotating element can easily be removed from the casing without disconnecting the electrical wiring or

## FACILITIES STANDARDS MANUAL

---

disassembling the motor, impeller, back-head or seal, so that any foreign object may be removed from the pump or suction line.

8. The pump shaft shall be sealed against leakage by a single mechanical seal constructed so as to be automatically drained and primed each time the pump is drained and primed. Water which lubricates the mechanical seal shall be automatically drained from around the seal if the pump loses prime, in order to allow both the pump and the seal to be drained, thereby preventing freezing and breakage of the seal during power outages in sub-freezing temperatures.
  9. The seal shall be of carbon and ceramic materials with the mating surfaces lapped to a flatness tolerance of one light band. The rotating ceramic shall be held in a mating position with the stationary carbon by a stainless steel spring.
  10. The pump casing shall be furnished with mounting lugs and bolted to the station floor plate, forming a gas-tight seal.
- k. Sewage Pump Motors.
1. The pump motors shall be vertical, solid shaft, specially built NEMA P-base, squirrel-cage induction type, suitable for three (3) phase, sixty (60) cycle, at either 480 volt, 240 volt, or 208 volt electric current. They shall be Class F insulation, suitable for temperatures up to 105 degrees Celsius. Insulation temperature shall, however, be maintained below 80 degrees Celsius. The motors shall have normal starting torque and low-starting current, as specified by NEMA Design B characteristics. They shall be open drip-proof design with forced air circulation by integral fan. Openings for ventilation shall be uniformly spaced around the motor frame. Leads shall be terminated in a cast connection box and shall be clearly identified.
  2. The motors shall have a 1.15 service factor. The motors shall not be overloaded beyond their nameplate rating, at the design condition nor at any head in the operating range.
  3. The motor-pump shaft shall be centered, in relation to the motor base, within .005". The shaft run-out shall not exceed .003".
  4. The motor shaft shall equal or exceed the diameter specified under sewage pumps, at all points from immediately below the top bearing to the top of the impeller hub, shall not exceed six (6) inches. A bearing cap shall be provided for the bottom motor bearing. Bearing housing shall be provided with fittings for lubrication as well as purging old lubricant.
  5. The motor shall be fitted with heavy lifting eyes, each capable of supporting the entire weight of the pump and motor.

- l. Controls.

## FACILITIES STANDARDS MANUAL

---

1. The control equipment shall be mounted in NEMA Type 1 steel enclosures with removable access cover. The circuit breakers, overload reset buttons, and control switches shall be operable without removing the access cover.
  2. Thermal magnetic air circuit breakers shall be provided for branch disconnect service and short circuit protection of all motor control and auxiliary circuits.
  3. Magnetic across-the-line starters with under voltage release and overload coils for each phase shall be provided for each pump motor to give protection against single phasing. Each single phase auxiliary motor shall be equipped with an over-current protection device in addition to the branch circuit breaker, or shall be impedance protected. All switches shall be labeled and a coded wire diagram shall be provided.
  4. To control the operation of the pumps with variations of sewage level in the wet well, and to control the automatic dialer alarms, five (5) mercury displacement switches shall be provided for the pumping station. These switches shall control: (1) pump lead; (2) pump lag; (3) pump stop/start initiate; (4) emergency pump stop/low level alarm; and (5) high water level alarm.
  5. To maintain pump prime, a vacuum priming system shall be provided for each pump in the pumping station. The pump priming system shall consist of two (2) vacuum pumps, vacuum control colenoid valves, and prime level sensing probes.
  6. An automatic alternator with manual switch for the pumping station shall be provided to change the sequence of operation of the pumps every eight (8) hours. The manual switch shall allow for either pump to be selected as base pump or for automatic alternation.
  7. Provisions shall be made for the pumps at the pumping station to operate in parallel should the level in the wet well continue to rise above the starting level of the low level pump.
  8. Phase monitoring shall be provided on the power feed lines to each pump motor. The phase monitors shall sense any change in phasing, or the loss of any phase, and shall interrupt the circuit to the pump motors so as to protect the pump motors. Upon loss or change in phasing, the phase monitors shall continue to monitor the power feed lines and, if proper phasing resumes, reset so that the pumps may continue operation.
- m. Wiring.

The pumping station shall be completely wired at the factory except for the power feeder lines. All wiring in the pumping station shall be coded as indicated on the wiring diagram. Wiring diagrams matching the unit wiring shall be provided.

# FACILITIES STANDARDS MANUAL

---

n. Factory Tests.

1. All components of the pumping station shall be given operational tests of all equipment at the factory to check for excessive vibration, for leaks in all piping or seals, and for correct operation of the control systems and all auxiliary equipment.
2. The pump suction and discharge lines shall be coupled to a reservoir and the pump shall re-circulate water under simulated service conditions.

o. Spare Parts.

A complete replacement pump shaft seal assembly shall be furnished with the pumping station. The spare seal shall be packed in a suitable container and shall include complete installation instructions.

p. Guarantees and Warranties.

1. The manufacturer of the pumping station shall guarantee for one (1) year from the date of acceptance of the operational pumping station by the Town of Culpeper that the structure and all equipment will be free from defects in design, material and workmanship.
2. Warranties and guarantees by the suppliers of various components in lieu of a single source responsibility by the manufacturer will not be accepted. The manufacturer shall be solely responsible for the guarantee of the pump stations and all components.
3. In the event a component fails to perform as specified or is proven defective in service during the guarantee period, the manufacturer shall provide a replacement part without cost to the Town.

q. Installation, Operation and Maintenance Manuals.

Four (4) copies of the installation, operation and maintenance manuals specific to the installed pumping station shall be delivered to the Town prior to acceptance of facility.

r. Wet Well Aeration

The pumping station manufacturer shall provide an aeration system for the pumping station to prevent septicity in the wet well. The system shall contain complete controls, duplex oil-less compressor, connecting hardware, diffuser, and spare parts. The control panel shall be in a NEMA 3R enclosure and shall contain necessary switches for manual selection of compressors, running lights, seven (7) day timer with fifteen (15) minutes adjustable increments. The compressor shall be oil-less with a minimum capacity of 0.3 CFM at 10 psi, and rated for continuous duty. A motor driven or electronic timer shall be provided in the controls to alternate the

# FACILITIES STANDARDS MANUAL

---

compressors every ten (10) minutes. A stainless steel diffuser shall be provided and shall connect by flexible nylon tubing to allow for easy removal and cleaning.

s. Alarm System.

1. An alarm system shall be provided by the pumping station to alert the Town of certain emergency conditions that may occur periodically. The alarm unit shall be DiaLog Plus 4 Automatic Dialing Alarm Systems, by ODESSA Engineering. The unit shall be supplied with the optional 24-hour battery. An acceptable surge protection device shall be provided on the electrical and telephone circuits to the alarm system. The following conditions shall be monitored by the alarm system.
  - a. High wet well level
  - b. Low wet well level (below low level pump off control)
  - c. Loss of primary commercial power or phasing
  - d. Pump failure
2. A red strobe light shall be mounted on the exterior of the building adjacent to the entrance door. This light will activate in sequence with any of the stated alarm conditions.

t. Telecommunications.

The developer shall contract with the telephone utility provider for service, and shall be responsible for any fees associated with providing a dedicated telephone line to the pumping station. Upon the issuance of an occupancy permit, the telephone service shall be placed in the name of the Town of Culpeper. The dedicated telephone line shall be terminated on the interior wall of the pumping station on an RJ11C jack. The automatic dialing alarm equipment shall be connected to the telephone jack. The Town will make the required recordings for outgoing alarm messages.

## **Sec. 2.730. Abrasive waste interceptors.**

Interceptors shall be provided for the proper handling of abrasive waste materials when deemed necessary by the Town of Culpeper, provided, however, that such interceptors shall not be required for private living quarters or dwelling units. All abrasive waste interceptors shall be of a type and capacity approved by the Town of Culpeper, and shall be located so as to be readily and easily accessible for cleaning and inspection.

## **Sec. 2.740. Grinder pumps.**

Nothing in Section 2.720 shall prohibit grinder pumps for private systems that are maintained by the property owner.

# FACILITIES STANDARDS MANUAL

---

## CHAPTER 3. TRANSPORTATION

### Sec. 3.100. Generally.

The purpose and intent of this Manual is to establish minimum standards for the planning, design, and construction of public streets within the Town of Culpeper. The Manual is divided into sections which establish guidelines and criteria for Transportation Planning, Design and Construction Standards, and Sidewalks and Trails. It is the intent of the Town of Culpeper that all roads be dedicated for public use and maintained by the Town of Culpeper pursuant to Section 33.1-224 of the Code of Virginia, except private streets as provided by the Zoning Ordinance.

### Sec. 3.110. Definitions.

*Alley* means a public or private way permanently reserved as a secondary means of access to abutting property.

*Building line* means the distance which a building is from the front lot line or front boundary line.

*Cul-de-sac* means a street with only one (1) outlet and having an appropriate turnaround for a safe and convenient reverse traffic movement.

*Easement* means a grant of one or more property rights by the owner to, or for the use by another specified party or parties, such as the public, a corporation, or another person or entity, including easements appurtenant and easements in gross.

*Highway engineer* means the resident engineer employed by the Virginia Department of Transportation (VDOT).

*Jurisdiction* means the areas of territory subject to the legislative control of the Town Council.

*Land surveyor* means a surveyor properly licensed by the Commonwealth of Virginia.

*Landing* means that section of a roadway which is adjacent to an intersection and utilized for vehicle stacking. Break-over is the difference in grade between two intersecting roadways.

*Lot* means a designated parcel, tract or area of land established by plat, subdivision, or otherwise permitted by law, to be separately owned, used, developed or built upon.

*Lot, corner* means a lot abutting two (2) or more streets at their intersection where the interior angle of the intersection does not exceed one hundred thirty-five (135) degrees. The front shall be deemed to be the shortest of the sides fronting on streets.

*Lot, depth of* means the average horizontal distance between the front and rear lot lines.

*Lot, double frontage* means an interior lot having frontage on two (2) streets.



# FACILITIES STANDARDS MANUAL

---

*Private accessway or street* means private vehicular facilities in residential townhouse and multifamily areas which serve the following functions: 1) provide for parking and 2) carry predominantly on-site traffic.

*Professional engineer* means an engineer properly licensed by the Commonwealth of Virginia.

*Right-of-way* means the total width of the strip of land dedicated or reserved for public travel, including roadway, curbs, gutters, sidewalks and planting strips.

*Street or road* means a public or private thoroughfare which affords the principle means of access to abutting property.

*Street, half* means a portion of a street built on or straddling a property line.

*Street, principal arterial* means the most significant streets in the urban area that serve the major centers of activity, constitute the highest traffic volume corridors, serve the longest trip desires, carry the major portion of through traffic in the urban area, and provide continuity between rural arterial roadways.

*Street, minor arterial* means streets which interconnect and supplement the principal arterial system with a greater emphasis on land access and a lower level of traffic mobility. They provide intra-community service as well as connecting rural collectors to the urban highway system.

*Street, urban collector* means the streets that provide land access service and traffic circulation within residential, commercial, and industrial areas. They collect local traffic and distribute it to the arterial system.

*Street, local* means streets that provide access to adjacent land and provide access to the higher systems. Service to through traffic is discouraged.

*Street or alley, public use of* means the unrestricted use of a specified area or right-of-way for ingress and egress to two (2) or more abutting properties.

*Street, service drive* means a public right-of-way generally parallel and contiguous to a major highway, primarily designated to promote safety by eliminating promiscuous ingress and egress to the rightof-way by providing safe and orderly points of access to the highway.

*Street, width* means the travelway between the edge of street pavement or edge of street curb.

## **Sec. 3.200. Transportation planning.**

- a. General requirements.
  1. Roadway Classifications
    - a. Public Roads: Public roads constructed in conjunction with subdivision and site plans shall be designed to comply with the standards of the Virginia Department of Transportation (VDOT) and the Facilities Standards Manual (FSM).
    - b. Private Roadways and Accessways

# FACILITIES STANDARDS MANUAL

---

## 2. Facility planning guidelines.

- a. The roadways within and contiguous to any development shall be designed and constructed so as to ensure coordination with other existing and planned roads within the general area as to arrangement, character, extent, width, grade, location, and drainage. Existing and planned roads shall be deemed to include, without limitation, roads depicted in the Comprehensive Plan and existing and planned roads in existing and/or future adjacent subdivisions and contiguous to adjacent subdivisions.
- b. When a subdivision or other development site abuts one side of any public road, the subdivider may be required to dedicate one-half of the total right-of-way or easements necessary to make such road conform to Town of Culpeper and VDOT standards. The subdivider may be required to dedicate more or less right-of-way or easement to make appropriate horizontal and vertical adjustments to such road.
- c. Vehicular access from off road parking and service areas shall be so combined, limited, located, designed, and controlled so as to channel traffic from and to such areas conveniently, safely, and in a manner that minimizes traffic friction and promotes free traffic flow on roads without excessive interruption.
- d. Whenever a proposed development contains or is adjacent to an arterial or major collector road, direct access shall be evaluated and the Director may require that provisions be made for the future elimination or reduction of direct access through methods such as the creation of a parallel road system, combined lot access, and other methodologies as determined appropriate.
- e. Reserve strips (spite strips) controlling access to public roads shall be prohibited.
- f. No more than eighty (80) dwelling units shall be served by a single point of access to a publicly maintained roadway via an appropriate access easement, unless a Comprehensive Plan containing such access easement and point of access has been approved.

## b. Traffic studies.

The following standards shall apply to traffic studies which are required of developments subject to the Code of Virginia Section 15.2-2222.1, as amended, or when deemed necessary by the Director. The AM/PM peak period traffic counts shall not be more than twelve (12) months old at the time of the complete application submission. Waiver or modification of the study requirements for rezoning and conditional use permit applications shall be administered by the Director. Applicants are encouraged to meet with the Town of Culpeper staff prior to the traffic study's preparation in order to establish the minimum scope for the assessment of the transportation system infrastructure to serve the subject project.

Traffic studies shall be used by the Town of Culpeper to assist in the coordination of the development's traffic with the local road network within or adjacent to the subdivision, and to determine the extent to which and the manner in which the proposed roadways in the subdivision shall be graded or otherwise improved.

# FACILITIES STANDARDS MANUAL

---

Traffic studies shall include:

1. Study Area: Roadways internal or adjacent to the development site shall be included in the traffic study. Other external roads shall be included to the extent that the project's generated traffic constitutes at least fifteen (15) percent of the road's current/existing traffic volumes (at the time of application). The area so defined shall constitute the study area.
2. Traffic Count Locations: Traffic counts are required on the adjacent roads, the adjacent intersections beyond the project's frontage and on adjacent streets in the study area.
3. Trip Generation: As a general guide to vehicle trip generation, the Institute of Transportation Engineer's (ITE) Trip Generation Report shall be used. These rates may be supplemented by additional information provided by the Town of Culpeper. If the applicant chooses to use different rates, they shall be documented and agreed to by the Director prior to their use in the traffic analyses.
4. Traffic Volume Projections: The traffic study shall provide existing and projected traffic volumes, with and without the subject project, for average daily traffic (ADT), as well as AM and PM peak hours. The peak hour of the project/individual land use(s) (as given in the ITE Trip Generation Report) should be added to the peak hour of the adjacent roadway traffic volumes (to show the worst case scenario), if the peak hour of the project/individual land use(s) is greater than the peak hour of the adjacent roadway (per ITE Trip Generation Report). The existing peak hour of traffic on the streets adjacent to the project site shall be identified. These traffic volumes shall be provided at street intersections and commercial or private accessways/entrances.
5. LOS Analyses: Level of Service (LOS) calculations for existing and projected conditions, with and without the subject project, for highway segments, intersection legs, and entrances shall be provided. Calculations shall be in accordance with the Highway Capacity Manual (HCM) and/or the Highway Capacity Software (HCS) or as may be accepted by the Director. Traffic volumes and level of service information shall be provided for each phase of development, to include conditions at date of project completion. Projections shall also be made for date of completion plus ten (10) years.
6. Minimum Roadway/Intersection LOS Standards: Recommendations for phased improvements to the road network links in order to maintain an acceptable level of service (minimum LOS "D") shall be provided. For each phase, a minimum approach and overall LOS "D" at intersections shall apply.
7. Background Traffic Assumptions: Assumptions which determine projected background traffic, including through traffic growth rate to be applied on roadway links, shall be confirmed in writing by the applicant prior to the start of the study. Specific other approved development names and respective development square footage or residential units used in the study shall be provided.
8. Traffic/Trip Distribution: Directional trip distribution information shall be provided for project entrances and collector and arterial intersections within the study area for the phases of development.

# FACILITIES STANDARDS MANUAL

---

9. LOS Calculation Assumptions: Traffic counts and level of service (LOS) worksheets and projected traffic volume level of service (LOS) analyses, including existing AM/PM peak hour signal timing, shall be included as a part of the traffic study.
10. Hazardous Locations: Road safety hazards, as identified by the ISTEA set-aside funding criteria, within the study area shall be identified and analyzed for all roadway links, and signalized as well as unsignalized intersections in the traffic study.
11. Mode Choice: Modal split information shall be provided for the phases of the analysis, with sources of information identified (e.g., COG model).
12. Traffic Mitigation Measures: If trip reduction factors are used in the study, measures necessary to implement the reduction must be specified, with supporting documentation.

## **Sec. 3.300. Design and construction standards.**

The following standards are intended to protect the public health, safety and welfare in addition to enhancing transportation efficiency.

## **Sec. 3.310. Street design requirements.**

All streets in a proposed subdivision shall be designed and constructed in accordance with the following minimum requirements by the subdivider at no cost to the Town of Culpeper:

### a. Alignment and layout.

1. The arrangement of streets in new subdivisions shall make provisions for the continuation of existing streets in adjoining areas.
2. The street arrangement shall be such as to cause no unnecessary hardship to owners of adjoining property when they plat their own land and seek to provide for convenient access to it.
3. Proposed streets shall be extended by dedication to the boundary line of such property to conform with the recommendations of the Comprehensive Plan, major thoroughfare plan or to serve potential development on adjoining property.
4. All streets shall be properly integrated with the existing and proposed system of thoroughfares as provided in the Comprehensive Plan.
5. Half streets along the boundary of land proposed for subdivision shall not be permitted.

Whenever possible, streets should intersect at right angles. In all hillside areas, streets running with contours shall intersect at angles of not less than eighty (80) degrees, unless approved by the Director.

6. Street layout shall be designed in such a manner that:

## FACILITIES STANDARDS MANUAL

---

- a. All collectors and arterial streets shall be related to special traffic generators such as industries, business districts, schools, churches and shopping centers; to population densities; and to the pattern of existing and proposed land uses.
- b. In business and industrial developments, the streets and other accessways shall be planned in connection with the grouping of buildings, locations of rail facilities and the provision of alleys, truck loading and maneuvering areas and walks and parking areas so as to eliminate conflict of movement between the various types of traffic including pedestrians.

7. Intersection spacing shall be in accordance with diagram 3.1.

b. Limited access. Whenever a proposed subdivision contains or is adjacent to a limited access highway or primary arterial street, the subdivider shall limit access to such street by one (1) of the following means:

1. The subdivision of lots so as to back onto the primary arterial and front onto a parallel local street; no access shall be provided from the primary arterial, and screening shall be provided in a strip of land along the rear property line of such lots.
2. A series of cul-de-sac, U-shaped streets or short loops entered from and designed generally at right angles to such a parallel street, with the rear lines of their terminal lots backing onto the major arterial.
3. A marginal access or service road (separated from the primary arterial by a planting or grass strip and having access thereto at suitable points).
4. Any alternative that would meet VDOT urban standards for access design.

c. Approach angle. Streets shall be laid out in such a manner as to intersect as nearly as possible at right angles. Streets shall intersect at an angle of not less than eighty (80) degrees, unless the shall approve a lesser angle of approach for reasons of contour, terrain or matching of existing patterns (refer to diagram 3.2, entrance spacing).

d. Minimum widths. The minimum right-of-way widths for proposed streets, measured from lot line to lot line, shall be shown on the major thoroughfare plan, adopted by the Town Council, or if not shown on such plan shall be:

1. Arterial street, not less than eighty (80) foot right-of-way.
2. Collector street, not less than sixty (60) foot right-of-way.
3. Local street, not less than fifty (50) foot right-of-way.
4. Local service drives, not less than fifty (50) foot right-of-way.
5. Alleys, if permitted, not less than twenty (20) feet nor more than twenty-eight (28) feet with adequate truck turnaround.

## FACILITIES STANDARDS MANUAL

---

e. Construction requirements. The streets shall be graded and the pavement design shall be installed according to the width and specifications as recommended by VDOT and administered by the Director. Street alignments and classifications shall be consistent with the most recent edition of the Comprehensive Plan for the Town of Culpeper.

f. Grades. The grades of streets submitted on subdivision plats shall be approved by the Director. All streets shall be graded to the finish grade for the full width of the right-of-way. Street grades shall not exceed eight (8) percent.

g. Entrance site distance shall be approved by the Director (see diagram 3.8).

h. Acceleration and deceleration lanes.

1. Where a subdivision or new commercial development requires an entrance onto an Arterial or Collector street, as defined in the current Town of Culpeper Comprehensive Plan, the entrance or entrances shall be provided with acceleration and deceleration lanes, with connecting lane widening between entrances and exits, except where the full ultimate design section for the roadway has previously been built. The extent of the acceleration and deceleration lanes shall be as specified in the VDOT publication, Minimum Standards of Entrances to State Highways, both as to the length of lanes and tapers and to the width of lanes.
2. Acceleration and deceleration lanes may also be required on local streets where traffic volumes are such that additional traffic entering or leaving the street would cause undue hazard to the traveling public.
3. Curb and gutter will be required along all acceleration lanes, deceleration lanes, or other lane widening at entrances, exits, or along the frontage of new commercial, industrial, or subdivision development along the following roads: Route 15/29 north of the Mountain Run Bridge, Route 229 north of the Mountain Run Bridge, Route 29 south of Route 3 intersection, Route 3 east of Route 29, Route 15 south of Route 3, and Route 522 west of Main Street. (refer to diagram 3.3, which illustrates materials and construction guidelines).
4. Curb and gutter will also be required for up to the full parcel frontage if necessary to efficiently handle storm drainage or where prior development with curb and gutter on neighboring parcels would necessitate the continuation of curb and gutter to maintain a consistent cross-section along the roadway.
5. Acceleration and deceleration lanes shall be constructed in accordance with diagram 3.9

i. Cul-de-sac. Generally, minor terminal streets (cul-de-sac), designed to have one (1) end permanently closed. Each cul-de-sac shall be terminated by a right-of-way turnaround of not less than one hundred (100) feet in diameter. The geometry for a cul-de-sac or turn around shall have a radius of no less than 50 feet at the property line and no less than 40 feet at the face of curb or edge of pavement line. Other types of turnarounds may be considered for private roadways. (refer to diagram 3.5)

Cul-de-sacs must be at least 200 feet in overall length, including the turn-around and private access to at least three (3) occupied dwellings, which cannot be corner lots that have access to another street.

# FACILITIES STANDARDS MANUAL

---

j. Alleys. Public alleys are prohibited where land is subdivided. Private alleys may be provided for townhomes, multifamily, commercial or industrial subdivision if necessary for service uses, provided adequate turnaround for truck traffic is designated.

k. Private streets and reserve strips. No private streets shall be platted in any subdivision where any lot is less than three (3) acres, notwithstanding the provisions outlined in Section 27-53(e), town homes. Every subdivided property less than three (3) acres shall be served from a publicly dedicated street. There shall be no reserve strips controlling access to streets.

l. Street names. Proposed streets which are obviously in alignment with other already existing and named streets, shall bear the names of the existing streets. In no case shall the names of proposed streets duplicate existing street names, irrespective of the use of the suffix street, avenue, boulevard, drive, way, place, lane or court. Street names shall be indicated on the preliminary and final plans and shall be approved by the Zoning Administrator. Names of existing streets shall not be changed except by approval of the Town Council.

m. Identification signs. Street identification signs, conforming to the standards of Section 5.310 of this Manual, shall be installed at all intersections.

n. Curbs and gutters. The subdivider shall install curbs and gutters on both sides of all streets within his subdivision; except, private streets serving an R-E subdivision where no lot is less than one (1) acre, or, where the property is located within the Town of Culpeper's Watershed Protection District, streets shall be constructed without curb and gutter. The subdivider is required to perform third party testing of all concrete curb and gutter in accordance with VDOT standards.

o. A road which permanently ends with a cul-de-sac or turn-around (not including dead end roads which end at a temporary turn-around) shall not exceed the lengths set forth below. Measurement of the length shall be taken along the centerline from the road's intersection with an existing or proposed through road to the center of the cul-de-sac or turn around.

<b>Development Type:</b>	<b>Allowable Maximum Length</b>
Commercial, retail, industrial office	1500 feet
Multi-family residential	1000 feet
Single family residential	
Townhouse	1500 feet
Detached SFD	
Zoned one (1) unit per acre or greater density	2500 feet
Zoned less than one (1) unit per acre	3500 feet

Additional criteria for cul-de-sacs or turnarounds include:

1. Developments with a single point of ingress/egress shall provide a secondary point of access for emergency vehicle use if the length of road, measured along the centerline from the point of beginning of the ingress/egress to the front of the most remote lot, exceeds the maximum allowable length. Multi-phased developments, with an approved concept development plan or preliminary plat showing more than one ultimate point of access, shall not be required to meet this requirement for individual phases, sections or plats, on ultimately planned through roads.

# FACILITIES STANDARDS MANUAL

---

2. Length criteria as contained within this manual shall not be applicable for divided roadways with medians and the above criteria shall apply beyond the point where the divided section ends.

p. Landings shall be provided at intersections to ensure adequate grade and sight distance at intersections. The maximum grade along the landing shall not exceed three (3) percent or the cross slope of the intersecting road, whichever is greater. Break-over shall not exceed six (6) percent. The minimum length of landing shall be fifty (50) feet. (refer to diagram 3.4)

q. On curb and gutter sections, the roadway right-of-way, or easement where applicable, shall extend a minimum of six (6) feet beyond the face of curb so that drainage structures can be accommodated. (refer to diagram 3.3)

r. Starting and stopping points of guardrail, as well as additional installations at hazardous locations, will be designated by the Director.

s. Signage and fire lane marking shall be in accordance with this Manual.

t. Flexible pavement sections shall be designed in accordance with available soils information with a CBR value consistent with local soil bearing materials and so noted on the plan.

u. Commercial entrance specifications are illustrated in diagram 3.7.

v. Intersection treatments/pedestrian crosswalks shall be required at all street intersections and leading to buildings. Refer to diagrams 5.4 and 5.7.

## **Sec. 3.320. Public roadway standards.**

a. Public roadways shall be designed to conform to the requirements of the applicable Virginia Department of Transportation (VDOT) standards and this Manual, except as specifically modified in writing by the Town Manager.

b. Where this article and the standards of VDOT may differ, the more restrictive requirements shall apply.

c. Public roadway construction plans and profiles require review and approval by the Town of Culpeper. Whenever no parking signs are posted, such signs shall be in accordance with diagram 3.7-1 of this manual.

d. Surface asphalt shall be installed on public or private streets as soon as weather permits for all developments. Final surface asphalt shall be installed prior to issuance of 50% of the zoning permits for homes constructed on a given roadway or prior to issuance of 10% of the occupancy permits for homes constructed on a given roadway, whichever comes sooner.



# FACILITIES STANDARDS MANUAL

## Sec. 3.330. Private streets and accessways.

Design of private streets and private accessways shall meet the minimum standards as defined below and shall require construction plans and profiles or site plan submissions, whichever is applicable. Private accessways shall be used only where a volume of less than 1,000 ADT is anticipated. Private accessway design standards do not apply to commercial parking lots.

**TABLE I**

Type	Traffic Volume (ADT)	Travelway Width (2-way)	Travelway Width (1-way)	Centerline Curve Radius (Degrees)	Stopping Sight Distance	Maximum Grade
1	1-250	24 ft.	18 ft.	22	200 ft.	8%
2	251-750	24 ft.	18 ft.	12	200 ft.	8%
3*	751-1000	24 ft.	18 ft.	12	275 ft.	8%

\*Angle parking is not allowed. Parallel parking is allowed on private accessways with additional pavement in accordance with the standards established in this Manual.

- a. Construction of private streets and accessways shall be inspected by qualified professional personnel. Tests (compaction, CBR, etc.), as required to determine conformance with approved plans and specifications, shall be completed by the owner/developer at no expense to the Town of Culpeper. Upon completion of construction, the owner/developer shall furnish the Town of Culpeper with a completion certificate, signed and sealed by the supervising professional. The completion certificate shall certify that construction has been completed in accordance with the approved plans and specifications and all applicable local, State and Federal regulations.
- b. An intersection is defined as the juncture of at least three segments of streets at a common point.
- c. Private accessway intersections onto a public or private street shall not be placed closer than one hundred (100) feet at centerline.
- d. No parking shall occur for a minimum distance of thirty (30) feet from an intersection, measured from the flow line of the gutter pan. For three (3) segment intersections, parking is allowed along the through street opposite the intersecting street, if width allows.
- e. Private streets shall not have a posted speed in excess of 15 mph.
- f. Travelway widths excluding parking shall be measured from face of curb to face of curb.
- g. The minimum pavement section for private streets and parking areas shall be based on the projected average daily traffic volumes using the VDOT Subdivision Street Requirements if the ADT exceeds two hundred fifty (250) vehicles per day (VPD).

# FACILITIES STANDARDS MANUAL

---

- h. The minimum pavement section for all private streets and accessways (except residential driveways) shall consist of six (6) inches compacted VDOT type 21-A stone, three (3) inches BM-25 (base asphalt) and two (2) inches of SM-9.5 (surface asphalt).
- i. A permanent cul-de-sac shall be required at the end of all dead-end roadways, which shall be constructed in accordance with Section 3.310(i) of this manual.
- j. Driveways serving single family dwellings and private accessways shall not exceed a grade of 12%.

## Sec. 3.340. Pavement thickness design standards.

- a. All streets constructed in the Town of Culpeper's rights-of-way shall have a minimum cross-section consisting of six inches (6") compacted 21-A (base stone), three inches (3") BM-25.0 (base asphalt), and two inches (2") SM-9.5 (surface asphalt). If heavier cross-section is required, follow the guidelines stated herein.
- b. The methods and materials used in the construction of all roads shall conform to the current VDOT Road and Bridge Specification, unless herein modified.
- c. Thickness requirements for sub-base, base course, and top or surface course for public roads are shown in VDOT Subdivision Street Requirements. In general, the thickness design of asphalt pavements for public roads in subdivisions shall comply with the requirements of the Virginia Highway Research Council (VHRC) "Design Guide for Subdivision Road Pavements and Supplement in Virginia" by N. K. Vaswani, October 1973, as amended and "Recommended Design Method for Flexible Pavements in Virginia," by N. K. Vaswani, March 1993, revised. Design California Bearing Ratio (CBR) and Average Daily Traffic (ADT) values shall be determined through geotechnical investigations and transportation studies for the roadway improvement. Pavement design for VDOT primary roads in Town of Culpeper shall comply with the requirements of the VDOT Materials Division and Virginia Transportation Research Council publication entitled "Flexible Pavement Design Guide for Primary and Interstate Roads in Virginia".
- d. Preliminary sub-base depth and pavement design shall be based on an assumed design CBR value of six (6), if soil tests have not been performed. For private streets with an Average Daily Traffic (ADT) in excess of 750 vehicles per day, soil tests of the as-constructed sub-grade shall be performed for the actual determination of CBR value. The required sub-base thickness and pavement design may be modified prior to the placement of the sub-base.
- e. Pavement thickness referenced for private streets are minimum requirements and shall be increased to account for site specific conditions.
- f. Pavement design assumes that the number of Heavy Commercial Vehicles (HCV), consisting of trucks, buses, etc., with four (4) tires or greater, will not exceed five (5) percent of the total projected traffic. If the total projected traffic includes more than five (5) percent of such vehicles, an equivalent projected traffic shall be equal to  $ADT + [20 \times \text{Number of HCV over five (5) percent}]$ .

## FACILITIES STANDARDS MANUAL

---

g. The minimum pavement section for privately owned and maintained parking areas (including driveways aisles within parking areas) serving individual commercial or industrial parking lots shall consist of a six (6) aggregate base course, and a two (2") inch bituminous surface course.

h. Pavement in commercial areas shall be of a heavy duty design in the major cart-ways and loading areas, and at dumpster pads to accommodate the anticipated vehicle loads. A minimum six (6) inch depth 3000 PSI [20,684 kPa] concrete section with steel reinforcement over four (4) inches of aggregate shall be used for dumpster pad areas.

i. Alternative pavement design sections may be considered. A request for approval of special designs shall be submitted with the construction plans and profiles and shall include the basis of design, calculations in accordance with current accepted engineering procedures and a justification for the exception to these standards. Cross-sections less than stated in section 3.340(a) of this section will not be accepted. Technical information regarding the characteristics of the alternative materials of construction (e.g., brick or concrete pavers, pavement admixtures, etc.) shall be provided as part of the request. The request may be submitted either as an integral part of the construction plans and profiles or site plans or separately for consideration.

j. When using an alternative equivalent pavement, the following thickness layers shall apply for roadways in excess of one hundred (100) vehicles per day (VPD):

1. Minimum thickness of the aggregate layer used as a base in a one or two layer system is six(6) inches.
2. Minimum thickness of the aggregate layer used as a sub-base is four (4) inches.
3. Minimum thickness of the asphalt concrete base (BM-25.0 or BM-37.5) layer on top of the sub-base is three (3) inches.
4. Minimum thickness of asphalt concrete surface (SM-9.5) layer on top of bituminous concrete base (BM-25.0 or BM-37.5) or intermediate surface course (XK-X:) is one and a half (1 1/2) inch.
5. Minimum thickness of asphalt concrete surface (SM-9.5 layer on top of aggregate material (treated or untreated) is two (2) inches.
6. Minimum thickness of the soil stabilized layer (cement, lime, etc.) is six (6) inches.
7. The maximum thickness of the asphalt concrete surface (SM-9.5) for one (1) lift is two (2) inches.
8. For staged construction of the pavement surface, maximum thickness of the asphalt concrete surface (SM-9.5) is three (3) inches.
9. The depth of aggregate material shall be designated in no less than one-half (1/2) inch increments.
10. The aggregate thickness of the sub-base should not exceed twelve (12) inches.

# FACILITIES STANDARDS MANUAL

---

11. When asphalt concrete base size BM-37.5 is used, there shall be an intermediate course.

<i>SUPERPAVE mix</i>	<i>Min.-Max. (recommended) SUPERPAVE lift thickness</i>
SM-9.0A	1"-1.25" (1"/110 lbs/sy)
SM-9.5A	1"-1.5" (1.5"/165 lbs/sy)
SM-9.5D	1"-1.5" (1.5"/165 lbs/sy)
IM-19.0A	2"-3" (2"/220 lbs/sy)
BM-25.0	2.5"-4"

***Types of SUPERPAVE Mixes:***

<i>Mix Designation</i>	<i>Liquid Asphalt Type</i>	<i>Remarks</i>
SM-9.0A	PG 64-22	Use only for low volumes with few trucks, never directly on aggregate. (<1000vpd)
SM-9.5A	PG 64-22	SM-9.5 mixes are for general use. (<10,000 vpd)
SM-9.5D	PG 70-22	SM-9.5 mixes are for general use. (>10,000 vpd)
SM-9.5E	PG 76-22	For very heavy traffic loads (not subdivisions).
SM-12.5A/D/E	As SM-9.5A/D/E	Can handle traffic during construction.
IM-19.0A	PG 64-22	Traffic not permitted during construction.
BM-25.0	PG 64-22	

***Minimum Mix Temperatures:***

<i>Mix Type</i>	<i>Min. Mix Temperature</i>	<i>Min. Base Temperature</i>
A	250 degrees F	40 degrees F
D	270 degrees F	50 degrees F
E (M), (S)	290 degrees F	50 degrees F
BM Mixes	250 degrees F	35 degrees F

Note: Maximum mix temperature is 350 degrees F.

***Compaction of SUPERPAVE:***

- \* Recommend 3 rollers; one of which should be a minimum 10-ton
- \* "D" and "E" mixes may require vibratory mode not allowed by Special Provision, unless approved by the VDOT District Materials Engineer
- \* Roller Pattern and Control Strip (VTM-76)
- \* VTM-76 requires Cores/Plugs to verify densities.

# FACILITIES STANDARDS MANUAL

---

## Sec. 3.400. Parking standards.

### a. General Criteria

1. Pedestrian Safety. Traffic calming devices, to include but not be limited to, on-street parking, stamped asphalt pedestrian crossings, landscaping islands, and bump-outs shall be required in the Crosswalk Overlay Boundary (refer to new diagram 5.4). In all other areas of town, crosswalks shall be designed in accordance with the VDOT Guidelines for Installation of Marked Crosswalks.
2. Off-street parking shall be designed so it has access to a public street without impeding vehicular movement in that street. Off-street parking, other than for single-family units, duplexes, and townhouses on local or minor streets, shall be designed so that vehicles exit such areas without backing onto a street.
3. Off-street parking shall be designed so that vehicles can proceed without posing a significant danger to pedestrians or other vehicles. The Director of Planning & Community Development may allow accessways handling two-way traffic to be built to one-way traffic standards where aisles will be less than sixty (60) feet in length and where the number of parking spaces served will be less than five (5) spaces.
4. Except where the Town of Culpeper determines that adequate capacity in the storm drainage system to which the site is draining exists and is willing to accept the increased volume of runoff, no parking area shall be constructed in such a manner that a significant volume of surface water from the lot will be drained onto public streets or buildings. No parking area shall be constructed in such a manner as to increase the quantity or decrease the quality of the runoff to adjacent lots.
5. Adequate lighting shall be provided for parking areas utilized during night hours. Lighting shall not interfere with the use of nearby properties or the safe use of public streets.
6. No part of any parking area other than the driveway entrance exit shall be within four (4) feet of any right-of-way line or public sidewalk which is adjacent to the street right-of-way.
7. All parking areas shall be landscaped in accordance with the requirements of this Manual.
8. Plantings which meet the standards for screening set out in this Manual will be used to screen every parking area other than those serving single family and duplexes from an adjacent residential ("R") district. Fencing may be substituted for plantings with the Town of Culpeper's approval.
9. The minimum number of spaces required may be reduced where the Town of Culpeper has determined that the reductions are necessary to preserve a healthy tree or trees with a three (3) inch or greater diameter from being damaged or removed, and where the site plan provides for the retention of said tree or trees. This provision is intended

## FACILITIES STANDARDS MANUAL

---

to protect young trees. Large trees should be retained only where less than twenty-five (25) percent of the drip line of the tree is disturbed.

10. Parking stalls in paved areas shall be demarcated. Parking areas shall be properly maintained in all respects. Without limiting the foregoing, landscaping shall be kept healthy and well maintained, surfaces shall be free of potholes, lines marking parking stalls shall be distinct and clear.
11. Except as provided in the Zoning Ordinance, all open off-street parking areas (spaces and aisles) and drives connecting such areas with the street shall be surfaced and constructed with; a minimum of six (6) inches of number 21A aggregate base and a minimum of two (2) inches of bituminous surface course, or six (6) inches of concrete, or four (4) inches of brick or porous paving block placed on four (4) inches of number 21A aggregate base.
12. Where parking areas are exempt from the pavement requirements of this Manual, the Town of Culpeper may; a). require landscape aisles or spatial separations be provided every three (3) or more spaces where it finds it is desirable to ensure that the parking stalls will be readily identifiable to the users b). require the perimeter of the parking area, encompassing but not limited to the unpaved parking stalls and the side of any unpaved drive or aisle leading to said stalls, to be rimmed or edged with landscape timbers, railroad ties, brick, or curbing of adequate size where it finds that it is desirable to prevent erosion, or washing away of surfacing materials, or where it is necessary to assist the public in ascertaining the shape of the parking area.
13. The Town of Culpeper may require that porous paving materials be substituted for other surfaces in any portion of a parking area where it finds it is necessary to protect the root system of a tree or trees from damage.
14. Storage spaces and stacking lanes shall be surfaced to the same standards as the paved parking area with which they are associated.
15. There shall be three (3) types of passenger vehicle parking spaces for parking facilities or automobiles.
  - a. Standard car head-in parking.
  - b. Handicap accessible head-in parking.
  - c. Parallel parking.
16. Where off-street parking is required, parking areas shall be graded, well drained and provided with a surface of bituminous concrete or equivalent paving materials. All parking spaces shall be delineated and striped in accordance with this Manual.
17. Curb and gutter shall be constructed around the perimeter of all parking areas and interior landscaped areas.

# FACILITIES STANDARDS MANUAL

---

b. Parking Geometry

1. The following table shall represent the minimum size requirements for standard parking spaces. (Refer to the Zoning Ordinance for the required number of parking spaces per use.)

	<u>Width</u>	<u>Length</u>
Standard Head-In Parking	9 feet	18 feet
Parallel Parking	8 feet	22 feet

2. Aisle widths for standard car parking spaces shall be provided in accordance with the following: 90 degrees - twenty two (22); 60 degrees - eighteen (18) feet; and 45 degrees - sixteen (16) feet, with the length measured along the centerline of the parking space. A minimum aisle width of twenty five (25) feet shall be maintained adjacent to buildings.
3. The stall width for standard parking spaces when measured between stall striping may be reduced to eight (8) feet when spaces are separated by double line stripes set one (1) foot apart. (i.e., the pavement area of each space shall remain nine (9) feet.
4. Wheel stops or curbing may be provided for parking spaces; however, no reduction in stall length is allowed.
5. Parking spaces for handicapped persons and related access aisles, accessibility routes and signage for physically handicapped persons shall be provided in accordance with State and Federal requirements.
6. Parking lots shall provide for safe and functional traffic circulation.
  - a. Entrances to parking bays shall be located along the site accessway to avoid blockage of the public right of way by vehicles entering the site. No parking on a public street shall be allowed within thirty (30) feet of the entrance, measured from the flow line of the gutter pan.
  - b. The major site accessways shall be clearly defined, with a minimum aisle width of twenty five (25) feet measured from face of curb to face of curb at curb returns, and no direct angle parking shall be allowed where anticipated ADT's exceed 1500. Major site accessways shall accommodate SU-30 and WB-40 design vehicle movements without requiring change of direction. A hierarchy of on site travelways shall be maintained.
  - c. Retaining walls, screening, landscaping and building walls shall be protected from vehicle contact.
  - d. "Overhang" areas which are a part of the required parking space must be graded no higher than two (2) inches above the top of the curb, and must not be encroached by landscape plantings, signs or other obstructions.

# FACILITIES STANDARDS MANUAL

---

- e. Loading spaces and dumpster pads shall be accessible by the design vehicle with all parking spaces occupied.
- 7. Parking areas shall provide for safe pedestrian travel.
- 8. A permanent turn-around shall be required when the dead-end aisle exceeds five hundred (500) feet measured along the centerline of the dead-end aisle, from the last aisle or public roadway.
- 9. A required off-street parking space shall have a vertical clearance of at least six and one-half (6.5) feet.

## c. Loading Spaces

Commercial building sites shall provide for loading space in accordance with the Zoning Ordinance. An AASHTO-WB-50 design vehicle shall be accommodated on all commercial sites. Where the applicant can show cause for why these limits can be reduced, the Director may waive or modify the requirements of this Manual in accordance with sound engineering practices.

### 1. Single Unit Loading Space

- a. A single unit loading space shall be a minimum of fifteen (15) feet in width and thirty (30) feet in length and provide a minimum horizontal clearance of fifteen (15) feet; provided, however, that when loading spaces are located alongside each other, additional loading spaces need only be a minimum of twelve (12) feet in width.
- b. Uses which are required to provide a single unit loading space shall provide an entrance and circulation system which can accommodate an American Association of State Highway and Transportation Officials (AASHTO) SU-30 Design Vehicle.

### 2. Semi-Trailer Standard Loading Space

- a. Semi-trailer loading spaces shall be minimum of fifteen (15) feet in width and fifty-five (55) feet in length and provide a minimum horizontal clearance of fifteen (15) feet.
- b. Uses which are required to provide a standard or semi-trailer loading space shall utilize an AASHTO WB-50 design vehicle for planning the entrance and on-site circulation system.

3. Loading spaces shall be accessible to the design vehicle with no more than two (2) backing movements. The circulation pattern for the design vehicle should provide for forward movement only and shall discourage backing movements.

4. Loading and unloading areas shall be located and designed so that the vehicles intended to use them can maneuver safely and conveniently to and from a public right-of-way, and complete the loading and unloading operations without obstructing or interfering with any public right-of-way or without substantially obstructing or



# FACILITIES STANDARDS MANUAL

---

interfering with on-site parking and movement of vehicles. Loading and unloading areas shall be demarcated with appropriate restrictive signage.

5. No off-roadway loading area shall be located within any required front yard. Furthermore, no off-roadway loading area shall be used to satisfy the requirements for parking or stacking spaces. Loading areas shall be designed and located in a manner which does not interfere with the free circulation of vehicles within parking or stacking areas.
6. Loading spaces may be provided cooperatively for two or more uses, subject to the approval of the Director, where it is demonstrated that adjacent land uses can be adequately served by a shared loading facility and legal instruments ensuring the permanent availability of off-roadway loading for all such uses are recorded in the land records of Town of Culpeper.

## **Sec. 3.500. Pedestrian sidewalks and trails.**

### a. General Requirements

1. Sidewalks, trails, and/or bikeways shall be provided in accordance with the Town of Culpeper's Zoning and Subdivision Ordinances. Provisions for pedestrian traffic shall be accommodated in residential, office, commercial, and industrial areas and activity centers as described below:

Subsequent and applicable construction plans and profiles and site plan applications shall reflect sidewalks and/or trails as specified in the approved and preceding zoning, special exception or subdivision applications, whichever is applicable.

- a. Single family detached: Sidewalk on both sides of the roadway.
  - b. Townhouse, multi-family: Sidewalk in front of the units on both sides of the roadway and to parking areas.
  - c. Activity centers (playgrounds, pools, tot lots, recreation centers): Sidewalk or trail leading to the facility and/or crosswalks for safe pedestrian movement.
  - d. Office, commercial, and industrial areas: Sidewalk leading to facility and/or crosswalks for safe pedestrian movement.
2. Pedestrian walkway systems shall be required to extend to the property boundaries of the project and shall tie into existing systems and provide for future additions to ensure continuity of the pedestrian walkways. When the sidewalk or trail is located outside of the public right-of-way, it shall be contained within a public access easement having a minimum width of six (6) inches wider than the sidewalk or trail on both sides. Areas zoned for industrial uses, however, are not required to construct sidewalks along streets internal to the industrial subdivision.
  3. Sidewalks, trails, and/or bikeways shall be constructed on a sub-grade compacted to 95 percent density at optimum moisture content. Construction of all concrete sidewalks shall require third party testing within right-of-way or public easement, in accordance with VDOT standards.

## FACILITIES STANDARDS MANUAL

---

4. Sidewalks, trails, or bikeways shall be constructed to one of the following cross-sections:
  - a. Adjacent to roadway: VDOT Type A-3 concrete to a minimum depth of four (4) inches on four (4) inches compacted VDOT type 21-A stone on a compacted subgrade.
  - b. Not adjacent to roadway: Crushed stone (VDOT Type 21-A) , four (4) inches thick topped with one and a half (1 1/2") inches of asphalt concrete (VDOT Type SM-9.5).
  - c. Not adjacent to roadway on well drained soils: Four and one-half (4 1/2) inches of asphalt concrete (one and a half (1 1/2) inch of (VDOT Type SM-9.5) on three (3) inches VDOT Type BM-25.0.
  - d. Not adjacent to roadway: Concrete pavers on a one (1) inch sand bed with four (4) inches compacted sub-base (VDOT 21-A) may be substituted with approval from the Director.
5. The maximum cross slope allowed shall be one quarter (1/4) inch per foot.
6. Where sidewalks and/or trails are provided in industrial developments, they shall comply with the standards included in this Manual.

### b. Sidewalks

1. The sidewalk longitudinal slope shall be consistent with the adjacent roadway. Where stairs are employed, handicapped ramps shall also be provided as necessary to comply with VDOT and ADA regulations.
2. Sidewalks shall be built with a minimum six (6) foot planting strip between the back of curb and the edge of sidewalk to the extent possible. Trees and pole mounted lights should be placed within the planting strip. Refer to diagram 6.8.
3. VDOT standards for CG-12 handicap accessible ramps shall be provided at pedestrian roadway crossings on curb and gutter roadway sections.
4. Sidewalks shall have a minimum unobstructed hard surface width of five (5) feet.
5. All buildings, the eaves or porches of which project over a sidewalk, shall be provided with gutters so that there shall be no drippings from the eaves, porches or gutters upon the sidewalk.
6. No water from any lot, gutter or spout shall be permitted to flow across the sidewalk or footpath of any street except in a covered drain, the cover of which shall not be above the surface of such footpath or sidewalk. Such drain shall be of sufficient capacity to convey the water to be received by it and shall be built, kept open and kept in good repair by the owner or occupant of the premises which it drains.
7. Awnings shall be at least two (2) feet back of the face of the curb. Any such awning, tree, etc., may only be so placed in the sidewalk area by permission and

## FACILITIES STANDARDS MANUAL

---

according to directions of the Town Manager. For the purposes of this manual, the term “sidewalk area” shall include both the sidewalk on ground belonging to the Town of Culpeper and any ground belonging to private parties which is alongside of the sidewalk but not more than three (3) feet therefrom, and not enclosed.

### c. Trails

1. An interconnected trail system may be substituted for sidewalks with the prior written approval of the Town Manager in planned residential, commercial, and industrial developments which provide equal or improved access to buildings and dwelling within the same.
2. Pedestrian trails shall be constructed in accordance with section 3.500(a)(4) of this manual and shall have a minimum unobstructed width of eight (8) feet.
3. Where stairs are employed, handicapped ramps shall be provided as necessary to comply with VDOT and ADA regulations.
4. Trails may be allowed to cross roads or streams provided safety measures and design standards are provided as required by the Director.
5. A minimum separation between the edge of trail and vertical obstructions of two (2) feet shall be provided.

### d. Bikeways.

1. A bikeway may be substituted for sidewalks or trails with prior written approval of the Town Manager in planned residential and planned industrial developments which provide equal or improved access to buildings and dwellings within the same.
2. Bikeways are preferred in the following locations:
  - a. Along one side of principal or collector streets of planned residential subdivisions as determined by the Director.
  - b. Along one side of spine roads in planned industrial areas as determined by the Director.
  - c. Along integral parts of the town’s trail system as shown in the comprehensive plan.
3. Bikeways shall be constructed in accordance with section 3.500(a)(4) of this manual and shall have a minimum unobstructed width of eight (8) feet.

### e. Bicycle parking racks.

1. Commercial, Industrial, and Institutional Uses: For each five (5) parking spaces required, one (1) bicycle parking facility shall be provided, up to five (5) percent of the required number of parking spaces. For safety purposes, such facilities shall be in close proximity

# FACILITIES STANDARDS MANUAL

---

to the building's entrance and be clustered. This requirement does not apply to any detached single family dwelling site plan. Such facilities shall be paved and constructed in accordance with the Town's Facilities Standards Manual. Refer to diagram 5.6.

2. Townhouse, Multi-Family Use: For each three (3) units, one (1) bicycle parking facility shall be provided.

## **Sec. 3.600. Street names and numbers.**

a. A uniform system of numbering properties and principal buildings administered by the Zoning Administrator, as shown on the map identified by the title "Official Street Names and Property Numbering Map," which is filed in the office of the Zoning Administrator, is hereby established. This map and all explanatory matters thereon, is hereby adopted and made a part of this manual.

b. Assignment and posting of numbers.

1. All properties or parcels of land within the Town of Culpeper shall be identified by reference to the uniform numbering system adopted in this manual; provided, that all existing numbers of property and buildings not now in conformity with provisions of this manual shall be changed to conform to the system herein adopted with six (6) months from the date of notification of nonconformity by the office of the Zoning Administrator.
2. Each principal building shall bear the number assigned to the frontage on which the front entrance is located. In case a principal building is occupied by more than one (1) business or family dwelling unit, each separate front entrance of such principal building shall bear a separate number.
3. Numerals indicating the official numbers for each principal building or each front entrance to such building shall be posted by the property owner in such a manner as to be visible and distinguishable from the street on which the property is located.
4. Numbers will be assigned at intervals determined by the Zoning Administrator. Direction of streets will also be determined by the Zoning Administrator.
5. Even numbers shall be assigned to properties on the north side of the east-west streets and on the west side of north-south streets.
6. Numbers will be assigned to each proposed lot or tract on the surveyor's and Zoning Administrator's copies of subdivision plats by the Zoning Administrator.

c. Street number required for building permit: No building permit shall be issued for any structure until the owner or developer has procured from the Zoning Administrator the official number of the premises. Final approval of any structure erected or repaired shall be withheld until permanent and proper numbers have been affixed to such structure in accordance with the requirements stated above.

d. Administration of numbering system: The Zoning Administrator shall be responsible for maintaining the numbering system being guided by the provisions of this Manual. The office of the Zoning Administrator shall keep a record of all numbers assigned under this Manual.

# FACILITIES STANDARDS MANUAL

---

e. Street names: Street names, as shown on the map identified by the title “Official Street Names and Property Numbering Map,” are hereby declared the official names of such streets, unless officially changed by subsequent action of the Town Council, after referral to the office of the Zoning Administrator. New street names shall not duplicate or closely approximate street names already assigned.

## **Sec. 3.700. Mail Box Requirements.**

Mail boxes serving single family detached dwellings and two family dwellings shall be decorative and appropriate in design and location with the architecture of the development. Each mailbox is required to have the address number clearly posted on both sides of the box or structure.

Mail boxes serving townhouse, multifamily, and commercial developments shall be cluster mail boxes. The location and use of cluster boxes will be reviewed and approved by the Zoning Administrator after consulting with the local postmaster.

## **Sec. 3.800. Temporary Street Name Signs and Posting of Address.**

For emergency response purposes, temporary street name signs shall be provided and installed by the developer until completion of all public improvements or installation of permanent street name signs. Street name signs shall be of sufficient size and contrast as to be legible to emergency crews responding to fires, medical emergencies, and the like. During construction, building and house numbers shall also be visible from the street.

# FACILITIES STANDARDS MANUAL

---

## CHAPTER 4. RESERVED

## CHAPTER 5. MISCELLANEOUS DESIGN STANDARDS

### Sec. 5.100. Landscape plans.

a. Where required, or where deemed necessary by the Town of Culpeper as a part of a site plan, rezoning, conditional use permit or variance, an applicant shall submit a landscaping plan as specified within the Zoning Ordinance. The following general requirements and minimum standards shall apply for all required landscaping.

1. Existing tree cover within any proposed subdivision or development plan shall be retained when possible taking into account in the design of the improvements and grading of any property. Preservation of specimen trees shall be as set forth in section 27-163.
2. Existing trees preserved on the site may be used to satisfy the requirements for landscaping. Any existing tree used to meet the requirements of this Manual must be at least three (3) inch diameter, in healthy condition, and be protected from construction activity. Tree-trunk diameters are measured at 4-1/2 feet above ground on the uphill side of the tree.
3. The property owner is responsible for maintaining all required plant material in good health for a period of two (2) years after time of planting. The planting of trees and other plant material shall be done in accordance with the current edition of Standardized Landscape Specifications jointly adopted by the Virginia Nursery and Landscape Association and the Virginia Society of Landscape Designers.
4. All shade trees must be planted in accordance with subsection (d) of this article.
5. Landscaping shall not obstruct the view of motorists using any street, private driveway, parking aisles, or the approach to any street intersection so as to constitute a traffic hazard or a condition dangerous to public safety.

b. Required landscaping.

1. Street trees, as defined in the Town of Culpeper Zoning Ordinance, shall be required along existing and proposed streets for any commercial, residential, institutional or industrial development which is subject to site plan approval or not exempted or waived in the Town of Culpeper Zoning Ordinance, Section 27-157. Refer to diagram 6.8 – Typical Street Tree Planting. Berming and street trees shall be required along any four lane road or street in accordance with the Facilities Standards Manual.
2. The following landscaping shall be required for parking lots consisting of five (5) or more spaces added or constructed.

## FACILITIES STANDARDS MANUAL

---

- a. When a parking lot fronts on an existing or proposed street, trees shall be planted in accordance with Section 5.100(d). An additional row of small shrubs shall be required between the street and the parking lot consisting of at least one (1) small shrub for every five (5) feet, or portion thereof, of street frontage.
- b. Interior landscaping for parking lots shall consist of two (2) shade trees and four (4) small shrubs for every ten (10) parking spaces, or portion thereof. Plantings may be appropriately dispersed as approved by the permit issuing authority. Plantings located along building foundations and around the base of freestanding signs may be used to satisfy the requirements of this section.
- c. Vegetative screening.

Vegetative screening or berming shall be required at all side and rear yards when a professional, commercial, industrial, multifamily or townhouse use abuts a single family detached residential use or zoning classification. Vegetative screening or berming shall also be required between multifamily and townhouse uses. Screening shall not be required when abutting an existing or proposed street, in which case the street tree requirements of Section 5.100(d) shall apply. For screening purposes, the use of berming will result in a 33% reduction of the required number of vegetative elements. (Refer to Diagram 5.8) [Code section 27-159]

Rear yard landscaping, consisting of shrubs and/or trees shall be provided, and cover at least 20% of the rear yard at maturity, as defined.

d. Functional classifications and examples of trees and shrubs. All plant material shall meet or exceed the specifications established by the American Nursery and Landscape Standard for Nursery Stock (ANSI Z60.1-2004) or as may be amended. All plantings must be identified by botanical name as contained within Article VI of the Town of Culpeper Zoning Ordinance. Refer to the Town's Zoning Ordinance for a complete list of landscape plantings.

1. Large shade trees shall be planted along arterials, collectors, and major subdivision streets. These trees shall be spaced forty (40) feet on center. Large trees generally mature at more than 60' in height. These trees shall not be placed under overhead utility lines. Please refer to the list of approved species.
2. Medium shade trees shall be planted in local subdivision streets, both public and private, in median strips, and in open space. These trees shall be spaced twenty-five (25) feet on center along right-of-way. Please refer to the list of approved species.
3. Buffering and screening trees or large evergreen shrubs, as required in section 5.100(c), shall consist of one (1) row planted not more than ten (10) feet on center or two staggered rows planted not more than fifteen (15) feet on center. Please refer to the list of approved species.
4. Ornamental or flowering trees shrubs shall be planted, in median strips, at subdivision entrances, along primary road frontage, in courtyards, at intersections, or used adjacent to buildings. These trees shall be spaced twenty-five (25) feet on center along right-of-way. Please refer to the list of approved species.

## FACILITIES STANDARDS MANUAL

---

5. Medium-Small evergreen and deciduous flowering shrubs shall be planted along the edges of parking lots where a parking lot abuts a public street and adjacent to buildings. Tall ornamental grasses may be substituted for up to one-quarter (1/4) of shrubs on a landscape plan provided they do not interfere with sight distance from a public street. Please refer to the list of approved species.
6. The following list contains plant species that have been approved for use to meet the landscape requirements as set forth in Section 5.100. Plant materials may be substituted provided that the substitution is similar to habit and form (i.e. height, width, evergreen for evergreen, deciduous for deciduous) and approved by the zoning administrator. The zoning administrator may not reduce the required plant materials, but may approve an adjustment in their location elsewhere on the site.

### **Large Shade Trees**

*Acer platanoides*, Norway Maple  
*Acer rubrum*, Red Maple  
*Acer saccharum*, Sugar Maple  
*Fraxinus pennsylvanica*, Green Ash  
*Ginkgo biloba*, Ginkgo Tree (male cultivar)  
*Liquidambar styraciflua*, Sweet Gum  
*Platanus x acerifolia*, London Plane Tree  
*Quercus coccinea*, Scarlet Oak  
*Quercus rubra*, Red Oak  
*Quercus palustris*, Pin Oak  
*Quercus phellos*, Willow Oak  
*Quercus shumardii*, Shumard Oak  
*Tilia cordata*, Littleleaf Linden  
*Tilia tomentosa*, Silver Linden  
*Ulmus parvifolia*, Lacebark Elm  
*Zelkova serrata*, Japanese Zelkova

### **Medium Shade Trees**

*Acer buergerianum*, Trident Maple  
*Betula nigra*, River Birch  
*Carpinus betulus*, European Hornbeam  
*Carpinus caroliniana*, American Hornbeam  
*Cercidiphyllum japonicum*, Katsura Tree  
*Cercis Canadensis*, Redbud  
*Crataegus phaenopyrum*, Washington Hawthorne  
*Koelreuteria paniculata*, Golden Rain Tree  
*Lagerstroemia indica*, Crape Myrtle  
*Ostrya virginiana*, American Hop Hornbeam  
*Oxydendron arboretum*, Sourwood  
*Pyrus calleryana*, Callery Pear  
*Syringa reticulata*, Japanese Tree Lilac

### **Flowering Ornamental Trees**

*Amelanchier arborea*, Serviceberry  
*Acer palmatum*, Japanese Maple



## FACILITIES STANDARDS MANUAL

---

*Cercis canadensis*, Redbud  
*Chionanthus virginicus*, Fringe Tree  
*Cornus florida*, Flowering Dogwood  
*Cornus kousa*, Kousa Dogwood  
*Cotinus coggyria*, Smoke Tree  
*Gledittea triacanthos*, Thornless Honey Locust  
*Lagerstroemia x L. Faurei*, Crape Myrtle  
*Magnolia soulangiana*, Saucer Magnolia  
*Magnolia stellata*, Star Magnolia  
*Magnolia virginiana*, Sweetbay Magnolia  
*Prunus serrulata*, Kwanzan Cherry  
*Prunus x yeodensis*, Yoshino Cherry  
*Vitex negundo*, Chaste Tree

### **Broadleaf Evergreen Trees and Large Evergreen Shrubs**

*Cephalotaxus harringtonia*, Plum Yew  
*Chamaecyparis lawsoniana*, Lawson Cypress  
*Cupressocyparis leylandii*, Leyland Cypress  
*Cryptomeria japonica*, Japanese Cedar  
*Ilex x attenuata 'Fosteri #2'*, Foster's Holly  
*Ilex cornuta 'burfordii'*, Burford Holly  
*Ilex glabra*, Inkberry  
*Ilex x Nelly R. Stevens*, Nelly R. Stevens Holly  
*Ilex opaca*, American Holly  
*Juniperous virginiana*, Eastern Red Cedar  
*Kalmia latifolia*, Mountain Laurel  
*Magnolia grandiflora 'Little Gem'*, Little Gem Magnolia  
*Myrica cerifera*, Southern Wax Myrtle  
*Myrica pensylvanica*, Northern Wax Myrtle  
*Photinia x fraseri*, Red Tip Photinia  
*Picea abies*, Norway Spruce  
*Pinus strobus*, White Pine  
*Rhododendron catawbiense*, Catawba Rhododendron  
*Thuja occidentalis*, Arborvitae  
*Viburnum x pragense*, Prague Viburnum  
*Viburnum rhytidophyllum*, Leatherleaf Viburnum

### **Medium-Small Evergreen and Decidious Flowering Shrubs**

*Abelia x grandiflora*, Abelia  
*Azalea x encore*, Encore Azalea  
*Berberis thunbergi*, Japanese barberry  
*Buddleia davidii*, Butterfly Bush  
*Buxus spp*, Boxwood  
*Callicarpa americana*, Beautyberry  
*Clethra alnifolia*, Summersweet Clethra  
*Euonymous alatus 'nana'*, Dwarf Burning Bush  
*Fothergilla gardenii*, Dwarf Fothergilla  
*Fothergilla major*, Fothergilla  
*Hydrangea microphylla*, Big Leaf Hydrangea

# FACILITIES STANDARDS MANUAL

---

*Hydrangea quercifolia*, Oak Leaf Hydrangea  
*Ilex cornuta 'burfordii nana'*, Dwarf Burford Holly  
*Ilex crenata*, Japanese Holly  
*Itea virginica*, Virginia Sweetspire  
*Leucothoe axillaris*, Coastal Leucothoe  
*Leucothoe fontanesiana*, Drooping Leucothoe  
*Nandina domestica*, Nandina  
*Pieris japonica*, Japanese Pieris  
*Prunus Laurocerasus 'Otto Luyken'*, Otto Luyken Cherry Laurel  
*Rhododendron calendulaceum*, Flame Azalea  
*Rosa x radcon*, Knock-Out Rose  
*Spirea x bumalda*, Bumald Spirea  
*Spirea japonica*, Japanese Spirea  
*Taxus x media 'densiformis'*, Dense Spreading Yew  
*Viburnum dentatum*, Arrowwood Viburnum  
*Viburnum plicatum var. tomentosum*, Doublefile Viburnum

7. Some trees on a site warrant special consideration and encouragement for preservation. These trees are referred to as specimen trees. When one or more specimen tree(s) are saved, one of the following incentives shall be applied towards the development:
  - a. A 25% reduction in required interior landscaping; or
  - b. A 10% reduction in total number of required parking spaces.

The following criteria will be used to identify specimen trees. Both size and condition criteria must be met for a tree to qualify.

## Size Criteria

Overstory hardwoods: 30-inch trunk diameter or larger (Oak, Maple, Hickory, etc.)

Overstory softwoods: 36-inch trunk diameter or larger (Pine, Cedar, etc.)

Flowering Understory trees: 12-inch trunk diameter or larger (Dogwoods, Redbuds, Magnolias, etc.)

## Condition Criteria

Life expectancy of greater than 15 years;

Relatively sound and solid trunk with no extensive decay;

No more than one major and several minor dead limbs (hardwoods only); No major insect or pathological problem.

The location and size of specimen trees to be saved on a site shall be identified on site plans being submitted for proposed developments. Tree protection fencing shall be shown on the plans to be installed around the specimen tree during construction to protect the tree and its roots from damage. Tree protection fencing shall encompass a circle with a diameter equivalent to one foot for each trunk diameter inch of the tree to be saved.

# FACILITIES STANDARDS MANUAL

---

Minimum plant sizes at time of installation.

Plant	Size	Height
Large shade tree	2½" caliper (min.)	6'-8' (well branched)
Medium shade tree	1½" caliper (min.)	4'-6' (well branched)
Buffering and screening	15 gallon, B&B	6'-8' (full)
Ornamental/flowering tree	1½" caliper (min.)	4'-6' (well branched)
Small evergreen shrub	3 gallon	18"-24" (full)
Large evergreen shrub	5 gallon	24"-60" (full)
Overhead utility tree	1" caliper (min.)	4'-6' (well branched)

e. Plant schedule to include: (Refer to Sample Landscape Planting Schedule below)

1. Key or symbol of plant material.
2. Plant name (botanical and common names required).
3. Quantity of each species. (caliper height).
4. Size
5. Type of root stock to be planted (balled and burlapped (B&B), container).
6. Reference the guidelines for planting and maintenance of the materials outlined in the current Virginia Erosion and Sediment Control Handbook.

### SAMPLE LANDSCAPE PLAN PLANTING SCHEDULE

<u>Key</u>	<u>Botanical Name</u>	<u>Common Name</u>	<u>Quantity</u>	<u>Size</u>	<u>Remarks</u>
C	Cornus florida	Flowering Dogwood	5	6'- 8'	B&B
Q	Quercus alba	White Oak	10	2 1/2" caliper	B&B
A	Acer rubrum	Red Maple	35	6'- 8'	B&B

### **Sec. 5.200. Erosion and sediment control.**

a. The Virginia Erosion and Sediment Control Handbook, this Manual, and Code of the Town of Culpeper Chapter 7, land disturbing activities, shall be the accepted references in the preparation of grading plans and erosion and sediment control proposals.

b. The use of diversion berms to break up drainage divides to support the use of sediment traps shall only be allowed where it can be demonstrated that maintenance of the berm can be accomplished during site grading activities.

c. The erosion and sediment control plan shall provide for two (2) phase erosion and sediment measures.

# FACILITIES STANDARDS MANUAL

---

1. The first phase shall reflect the perimeter controls and any interior controls necessary to protect undisturbed land areas and shall reflect existing conditions including drainage divides. Existing drainage divides shall be the basis to determine the use of sediment traps versus sediment basins.
2. The second phase shall reflect specific controls once the infrastructure and storm sewer pipes are installed. Future drainage divides shall be considered when designing this phase.

## **Sec. 5.300. Fire lane signs.**

a. Fire lanes may be established at shopping centers which voluntarily want to properly mark fire lanes. If fire lanes are voluntarily established, they shall not be less than eighteen (18) feet in width and run the length of the frontage of the building or any side where access to the building has been provided. Fire lanes shall be indicated by solid yellow line painted on the pavement, running the full length of the building and located not less than eighteen (18) feet from the frontage of the building.

b. Fire lanes shall be marked and posted with signs in such numbers and at such locations as authorized by the Chief of Police, reading as follows: "No Parking-Fire Zone." Such signs shall be purchased and installed by the shopping center owner. When signs are so installed, it shall be unlawful for any person to park any vehicle in such fire lane.

## **Sec. 5.310. Street name signs and posts.**

Street name signs shall be diamond or high intensity grade six (6) inch flat aluminum blanks with colors, lettering and design per diagram 5.1 installed on a square post cap. The sign post shall have breakaway capability. (refer to diagram 5.1a and 5.2)

## **Sec. 5.320. Handicap signs.**

Handicap signs shall be provided on the plans in accordance with the specifications set forth in the Americans with Disabilities Act of 1990, as amended. Parking spaces reserved for the handicapped shall be identified by both freestanding signs and pavement markings. (refer to 5.3)

## **Sec. 5.400. Monuments.**

a. As required by this Manual, all monuments shall be installed by the subdivider and shall meet the minimum specifications. Upon completion of final grades, the subdivider shall make certain that all monuments required by the agent are clearly visible for inspection and use. Such monuments shall be inspected and approved by the Director before any improvements are accepted by the Town of Culpeper and before release of the public improvements bond.

b. Monuments shall be an iron pin with a minimum diameter of 3/8 inch and a minimum length of eighteen (18) inches. Monuments shall be set at all points where the boundary lines change directions and at all points where the street lines change directions including points of curvature, and points of compound curvature. The top of the monument shall be set flush with the finished grade. When rock is encountered, a masonry nail or PK nail may be driven into the rock or a clearly defined hole drilled one (1) inch deep in the rock may be used to define the point.

---

# FACILITIES STANDARDS MANUAL

---

## **Sec. 5.500. Individual lot grading plans.**

Prior to the issuance of a zoning permit, individual lot grading plans are required for all new developments and such projects that require a site plan and/or major subdivision plan as set forth in chapters 22 and 27 of the Town Code. Lot grading plans are to be approved by the Director.

The purpose of a lot grading plan is to ensure that lots are graded in such a way that provides positive drainage without slopes being steeper than 3:1. Grading should not cause undo drainage problems or safety issues with the subject lot and adjoining properties.

The following general requirements and minimum standards shall apply for all lot grading.

1. A lot grading plan shall include the following information:
  - a. Boundary information (metes and bounds)
  - b. Structure locations and distance to property lines
  - c. A seal signed by the surveyor, engineer, or architect authorized by the Commonwealth of Virginia
  - d. Pre- and post-contour lines
  - e. Tax-map identification
  - f. Drainage patterns and areas
  - g. Adjoining land uses and property owners
  - h. Storm utilities
  - i. Location of water mains and sewer laterals
  - j. Setbacks
  - k. All easements
  - l. Percentage of driveway slope
  - m. Basement and first floor elevations
  - n. Spot shot at four corners of building
  - o. Impervious surface total for lots in the watershed
  - p. Retaining walls (Note: Any retaining walls that are regulated by code are required to be submitted as part of the lot grading plan.)

## **Sec. 5.600. Certificate of occupancy prerequisites in subdivisions.**

The purpose of this chapter is to establish minimum standards for completeness of a development prior to issuing certificates of occupancy.

It is the responsibility of the party requesting a Certificate of Occupancy prior to the inspection to ensure that the following items have been addressed in order to avoid re-inspection fees.

In order for a Certificate of Occupancy to be issued, the following must be completed.

1. Streets: Streets shall be hard surfaced in accordance with chapter 3 of this manual and shall be clean and free of any debris and mud.
2. Drainage: Drainage systems, closed or open, that directly affect the subject property shall be completed in accordance with chapter 4 of this manual and the approved site plans.

# FACILITIES STANDARDS MANUAL

---

3. Signage: All signage (i.e. street names, stop, no parking, and speed limit signs) shall be installed in accordance with VDOT standards, chapter 3 of this manual, and the approved site plan.
4. Grading: Subject property shall be graded in accordance with the approved site plan and the approved individual lot-grading plan. Property shall have positive drainage and not cause undo hazards to adjoining properties.
5. House numbers: House address numbers as assigned by the town shall be placed on the front of the structure in a manner clearly visible from the street.
6. Roof drainage: Roof water shall be dealt with in such a manner as not to cause erosion. The uses of underground piping or splash-blocks are recommended.
7. Yard stabilized: If a minimum of two (2") inches of top soil cannot be found on-site, then imported top soil needed to achieve 2" of top soil shall be placed on-site prior to installation of seed. If sod is provided, then no top soil is required. If electing to use the seed and mulch method, E&S control devices shall remain in place until the vegetation is established to the point as to eliminate erosion.
8. E&S: Erosion and sediment control devices shall remain in place until the vegetation is established to the point as to eliminate erosion. When the E&S devices are no longer needed, they shall be removed.
9. Paved driveway: Hard surface driveways shall be installed.
10. County final inspection: The subject property shall have passed the final building inspection conducted by the County of Culpeper.
11. Utilities: All utilities (i.e. water, sewer, electric, and cable television) shall be installed and all excavations shall be compacted, fine graded, and stabilized.
12. Landscaping: All landscaping shall be installed in accordance with the approved site plan. Provisions shall be made to ensure the health of the trees for a period of two years. For example, if trees are to be planted in late spring or summer, watering bags should be used to keep the trees healthy.

## **Sec. 5.700. Subdivision construction order.**

The purpose of this section is to establish the suggested order in which subdivisions are to be constructed.

1. Site plan submission and approval process: Code of the Town of Culpeper, Chapters 22 and 27
2. Final plat with bond approval: Code of the Town of Culpeper, Chapter 27
3. Individual lot grading plans.
4. Zoning permit (town approval)
5. Building permit (county approval)
6. Land disturbing permit: Code of the Town of Culpeper, Chapter 27

# FACILITIES STANDARDS MANUAL

---

7. E&S installation: FSM Section 5.2, E&S Handbook
8. Rough-grade the site to include the removal and storage of top soil on site: Approved site plan
9. Install utilities, water, sewer, electric, CTV: Approved site plan
10. Construct roadways: FSM, Chapter 3
11. Building construction.
12. Install signage: Approved site plan
13. Install landscaping: Approved site plan
14. Finish asphalt on all streets: FSM, Chapter 3
15. Obtain certificates of occupancy
16. Remove temporary E&S: FSM, Section 5.2, E&S Handbook
17. Conduct walk-through with town staff and correct all punchlist items prior to town acceptance and returning bonds.

## **Sec. 5.800. Inspection requirements.**

The purpose of this section is to establish when inspections are to be performed by town staff.

1. E&S installation: Inspected prior to grading and periodically during construction
2. Install utilities, water, sewer, electric, CATV: Inspected periodically throughout construction
3. Construct roadways: Inspected continuously throughout construction
4. Install signage: Inspected as part of the Certificate of Occupancy inspection
5. Install landscaping: Inspected as part of the Certificate of Occupancy inspection
6. Finish asphalt on all streets: Inspected continuously throughout construction
7. Certificates of Occupancy: Inspected at time of completion
8. Remove temporary E&S: Inspected prior to and after removal
9. Returning of bonds: Re-inspection of all above items prior to acceptance by the Town

## **Sec. 5.900. Placement of dumpsters.**

Dumpsters and refuse containers shall not be placed within any right-of-way of an existing or future public street, except as approved by the town manager.

## FACILITIES STANDARDS MANUAL

---

**Sec. 5.910. Safety fencing required.**

Exclusive of Article VI of this chapter, a six (6) foot metal or board-on-board fence shall be required between any residential development and adjoining commercial or industrial use or zoning district classification when, in the opinion of the zoning administrator, the adjoining properties or uses may pose a safety threat. This requirement shall also apply to any residential development that adjoins a railroad, embankment, or any other safety hazard.



# FACILITIES STANDARDS MANUAL

---

## CHAPTER 6. ELECTRICAL AND LIGHTING

### Sec. 6.100. Generally.

a. Generally.

Lighting levels, selection of poles, heights of mounting, type of luminaries, and placement of lights shall be in conformance with this Manual.

b. Applicable design standards.

Applicants are reminded that, in all cases, the applicable requirements of the current Virginia Uniform Statewide Building Code, National Electric Code, International Energy Conservation Code, and other State and Town of Culpeper Code and/or construction standards, where applicable, must be met. The applicant is referred to the codified ordinances of the Town of Culpeper, Chapter 4, Article II Building Permits, for permitting requirements.

c. Electric connections required.

All electric distribution and service facilities shall be installed underground unless a waiver is approved by the Town Manager. The Town Manager shall consider the purpose and intent of the manual, any hardship of the property owner, and the best interest of the Town in deciding whether to grant or deny a waiver. The Town of Culpeper will supply and meter at one delivery point on the basis of facilities provided by the Town of Culpeper to serve the demand requirements of the customer. Demand requirements greater than fifty (50) KW will be served by three (3) phase facilities.

d. Inspection - new service.

The Town of Culpeper will be obligated to supply electricity to a customer only when the following conditions shall have been complied with:

1. The customer's new installation shall have been made in accordance with the Town of Culpeper's installation requirements; and
2. The Town of Culpeper has received a certificate signed by the local inspection authority having jurisdiction certifying that the wiring on the premises of the customer has been installed in compliance with the requirements of the Virginia Uniform Statewide Building Code and such other requirements as may be fixed by such authority. All fees or other charges required to be paid in connection with the issuance of such certificates shall be borne by the customer.
3. All charges as specified in this Manual shall be paid prior to installation of meter.
4. In no event shall the Town of Culpeper be under any obligation to inspect the wiring, equipment or appliances of a customer.

# FACILITIES STANDARDS MANUAL

---

## Sec. 6.200. Location of Town of Culpeper equipment.

- a. As a condition of the Town supplying electricity, the owner shall permit the Town of Culpeper to install any poles, lines, transformers, or any other equipment on the property which, in its judgment, are necessary in supplying electricity to the customer.
- b. As a condition of the Town supplying electricity, the owner shall permit the Town of Culpeper to place its transformers and such other apparatus as may be needed in connection with supplying such electricity at a convenient point or points on the property or in the building or buildings on the property. All landscaping or structures shall maintain at least a 3' setback from the sides and rear of the transformer and 10' from the front of the transformer.
- c. As a condition of the Town supplying electricity, the owner or customer shall permit the Town of Culpeper to enter the premises of the customer at all reasonable hours for the purpose of making such inspection of the customer's installation as may be necessary for the proper application of the Town of Culpeper's rate schedule and ordinances; for installing, removing, testing or replacing its apparatus or property, for reading meters, and for the entire removal of the Town of Culpeper's property in the event of termination of service to the customer for any reason. The Town of Culpeper shall have the right to discontinue the supply of electricity without notice, should access to customer's premises not be provided.
- d. All property of the Town of Culpeper installed in or upon the customer premises used and useful in supplying service is placed there under the customer's protection. All reasonable care shall be exercised to prevent loss or damage to such property, ordinary wear and tear excepted.
- e. The customer will be held responsible for breaking the seal, tampering or interfering with the Town of Culpeper's meter or meters or other equipment of the Town of Culpeper installed on the customer's premises. No one except employees of the Town of Culpeper will be allowed to make repairs or adjustments to any meter or other piece of apparatus belonging to the Town of Culpeper.

## Sec. 6.300. Electric meters.

- a. The customer shall provide suitable space for the installation of the necessary metering apparatus. The space shall be:
  1. Substantially free from vibration.
  2. An outside location for all residential services unless otherwise approved by the Town of Culpeper. A side location is preferable for detached single family residential structures.
  3. An outside location, where practicable, for commercial, industrial, or large residential apartment premises. The location of which shall be approved by the Town of Culpeper.
  4. Readily accessible and convenient for reading, testing and servicing; unobstructed by overhangs, decks and shrubbery (see diagrams 6.6 & 6.7).
  5. Such that apparatus will be protected from injury by the elements or the negligent or deliberate acts of persons.

# FACILITIES STANDARDS MANUAL

---

b. All equipment furnished and installed by the Town of Culpeper shall be and remain the property of the Town of Culpeper.

c. Resale of electrical energy by the customer is not permitted.

## **Sec. 6.400. Plan requirements.**

a. All subdividers and developers shall submit a set of plans for proposed electric service.

b. The applicant shall prepare and submit plans which include the following information:

1. All existing property lines, existing streets and easements, and the location of existing utilities, if known.
2. All proposed property lines; proposed streets and easements and the location of proposed utilities, if known.

## **Sec. 6.500. Electric utility easements.**

a. Underground electric utility easements shall be a minimum of fifteen (15) feet in width. Overhead electric utility easements shall be a minimum of thirty (30) feet in width. The width of electric utility easements may increase depending upon the type of facility necessary. An electric utility easement will be required where necessary for the Town of Culpeper to locate its facilities on property not designated as a public right-of-way to serve the customer on whose property the facilities are to be located. Easements will also be required where it is necessary for the Town of Culpeper's facilities to cross over property not designated as a public right-of-way to serve other customers.

b. In the event that the Town of Culpeper's facilities are located on a customer's property to serve the customer, and if it becomes desirable to relocate these facilities due to expansion of the customer's building or other facilities, or for other reasons initiated by the customer, the Town of Culpeper will, where feasible, relocate its facilities at the customer's expense. The customer requesting relocation of existing facilities is responsible for all costs.

## **Sec. 6.600. Characteristics of electricity supplied.**

a. The Town of Culpeper normally provides single-phase, 60 hertz alternating current at approximately 120/240 or 120/208 volts, or three phase, four-wire at approximately 208Y/120 volts, and in some instances three-phase, four-wire at approximately 240Y/120 volts or 480Y/277 volts three-phase, fourwire. When other voltages are desired, the Town of Culpeper may, at its option, provide such service at the customer's expense.

b. The customer shall furnish a load letter describing the electrical requirements of each device to be installed and the total anticipated transformer demand requirements. Based on this information the Town of Culpeper will determine the size and rate of service. The Town of Culpeper will provide, upon written request, the available fault current at the customer's service location, and such information must be considered when selecting service entrance equipment.

c. To eliminate the possibility of error or loss, the customer, before purchasing motors or other equipment or undertaking to install wiring, should secure from the Town of Culpeper in writing all necessary

# FACILITIES STANDARDS MANUAL

---

data relating to the characteristics of the electricity and service connections which are supplied, or will be supplied in the future.

## **Sec. 6.700. Street and site lighting standards.**

a. In the interest of safety and security for persons, property and traffic, adequate lighting shall be provided in all proposed developments. Street lighting poles shall be installed within the street right-of-way to be dedicated to the Town of Culpeper, or within a maintenance and installation easement indicated on the record plat.

b. The complete installation shall be the property of the developer until such time as the street is accepted into the Town's street system by action of the Town Council. Upon acceptance, the Town of Culpeper will assume ownership of the lighting fixtures and all related attachments.

c. The standards established within this section are applicable to lighting required in conjunction with subdivision and/or site plan development. In addition, the light and glare performance standards established within the Zoning Ordinance shall be met, where applicable.

## **Sec. 6.710. General requirements.**

Construction plans and profiles and site plan submissions shall show the conceptual layout of the proposed lighting fixtures. The plans shall also include a narrative specifically outlining the proposed lighting standards and specifications, the parties responsible for the associated operation and maintenance costs and, if applicable, the permit requirements, as established in this Manual. Fixtures shall be located so as not to interfere with other utilities, and to minimize potential conflicts with building sites.

### **a. Residential Subdivisions/Site plans**

1. Street lighting shall be provided within all residential developments in accordance with the standards outlined in this Manual.
2. Site lighting shall be provided in accordance with the standards outlined in this Manual.

### **b. Retail, Commercial, and Office, and Industrial Subdivisions/Site Plans**

1. Street lighting shall be provided along all roadway frontage and along subdivision streets intersections in accordance with the standards outlined in this Manual.
2. Site lighting shall be provided in accordance with the standards outlined in this Manual.

## **Sec. 6.720. Lighting standards.**

### **a. Street Lighting and Parking Lot Lighting - Poles and Fixtures.**

1. Lighting located within commercial and industrial developments shall establish the mounting height, luminance, wattage per luminaire and spacing to provide a minimum average horizontal illumination of 0.4 foot-candles on the street/accessways. Residential and commercial site plans/subdivisions lighting poles and fixtures located within public right of way shall be in accordance with diagrams 6.0 through 6.3 of this manual or

# FACILITIES STANDARDS MANUAL

---

similar in appearance. All lighting poles and fixtures within the Town's Historic District shall be in accordance with Diagrams 6.3 of this manual.

2. Lighting located within commercial and industrial developments at subdivision street intersections shall establish the mounting height, luminance, and spacing to provide a minimum average horizontal illumination of 0.6 foot-candles on the streets and accessways.

b. Street light and parking lot standards:

1. The following lumen and distribution standards apply:

Streets	7000 to 8000 lumen, type II
T-intersection	7000 to 8000 lumen, type II
X-intersection	7000 to 8000 lumen, type II 4-way
Cul-de-sac	7000 to 8000 lumen, type V
Parking lots/walkways/entrances	7000 to 8000 lumen, type II

2. The following spacing and location standards apply:

Streets	Min. 150 feet, max. 300 feet between installations. Allowances may be made for curves.
T-intersections	At the top of the "T"
X-intersections	At one corner with arm angled toward the center of the intersection
Cul-de-sac	At the head of the circle
Parking	As needed to meet above lumen standards lots/walkways, etc

c. Lighting standards for parking lots, walkways and entrance areas.

1. Applicability: This section shall apply to each outdoor luminaire installed or replaced after the date of adoption of these regulations.
2. Standards: Exterior lighting shall be reasonably designed to provide for the safety of the public and their use of parking lots, walkways and entrance areas. These areas shall be illuminated by a source providing adequate light at the surface during the hours of darkness or business operation. Parking lights and fixtures shall be shielded in such a manner that all light emitted by the fixture does not cause glare or excessive light spillage onto neighboring sites. The spillover of lighting from parking area luminaires onto residential uses or zoning districts shall not exceed one-half (0.5) foot candle. The spillover of lighting from parking area luminaires onto all other uses and zoning districts shall not exceed one (1) foot candle.
  - a. Lighting poles and fixtures within public right of way for residential and commercial site plans shall be in accordance with diagrams 6.0 through 6.3 of this manual or similar in appearance.

Lighting poles cannot exceed eighteen feet (18') in height in residential developments and twenty-six feet (26') in height in non-residential developments.

# FACILITIES STANDARDS MANUAL

---

## CHAPTER 7. REFUSE COLLECTION

### Sec. 7.100. Generally.

The Town of Culpeper will make refuse collection as provided in Sections 7.200 and 7.300.

### Sec. 7.200. Residential.

Collection will be made on ground level, outside, from the curb or edge of the street abutting the premises of single and multifamily residences and apartment buildings. Any residential development or buildings of ten (10) or more units must provide dumpster service, excluding single family detached dwellings.

### Sec. 7.300. Commercial and industrial.

Collection will be made on ground level, outside from the rear or side of commercial and industrial premises. Collection will also be made from the front of the premises when the refuse receptacles are placed at the curb by the patron.

### Sec. 7.400. Screening of refuse and recycling containers.

All outdoor refuse containers or areas used for the storage or collection of refuse, including trash dumpsters and recycling containers, shall be screened from view of adjacent properties and the public right of way. Screening shall be obtained through the use of wooden or composite fences, walls, evergreen vegetation, earthen berms or a combination of these methods. Chainlink fences shall not be allowed for screening purposes. Double-bay enclosures, accommodating both refuse and recycling containers, are required where both are an integral part of the operation.

# FACILITIES STANDARDS MANUAL

---

## CHAPTER 8. REAR LOADING CONTAINERS

### Sec. 8.100. Scope of chapter.

This division provides for the collection of refuse in rear loading containers.

### Sec. 8.200. Specifications; purchase; maintenance.

Containers shall be the rear loading type specifically designed for the purpose. The size of containers shall be two (2) through eight (8) cubic yards. Containers shall have lids, drain plugs and, at the option of the Town of Culpeper, casters. The container user shall provide the container. Containers must conform to Town of Culpeper specifications and be approved by the Town of Culpeper before being placed into service. The Town of Culpeper will not accept responsibility for maintenance of containers.

### Sec. 8.300. Location.

Containers shall be located on the property to be served at a site approved by the Town of Culpeper. Container owners shall be responsible for seeing that there is sufficient space provided around the container for the operation of the collection truck.

### Sec. 8.400. Concrete platforms.

Containers shall be placed on concrete platforms furnished by the user and built to Town of Culpeper specifications. The platform shall be flush with the finished grade and shall be at least ten (10) feet by ten (10) feet by four (4) inches. The site shall be approved by the Town of Culpeper, and the forms for the concrete slab shall be inspected and approved before concrete is poured.







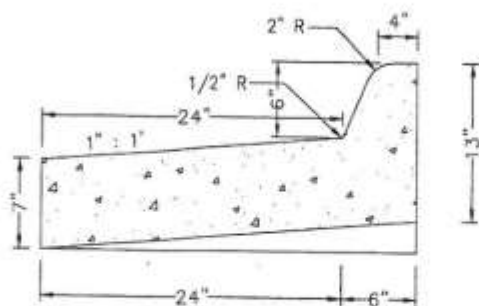

**CG-6R**  
REVERSED CURB & GUTTER  
(ONLY TO BE USED ON PARKING LOTS)

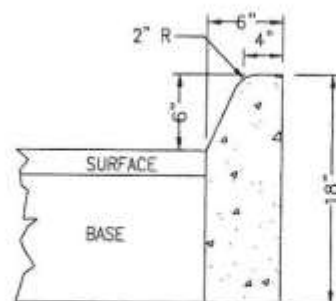

**CG - 2**  
MEDIAN CURB

THE DEPTH OF CURB MAY BE REDUCED AS MUCH AS 3" ( 15" DEPTH) OR INCREASED AS MUCH AS 3" ( 21" DEPTH ) IN ORDER THAT THE BOTTOM OF CURB WILL COINCIDE WITH THE TOP OF THE COURSE OF PAVEMENT SUBSTRUCTURE. OTHERWISE THE DEPTH IS TO BE 18" AS SHOWN

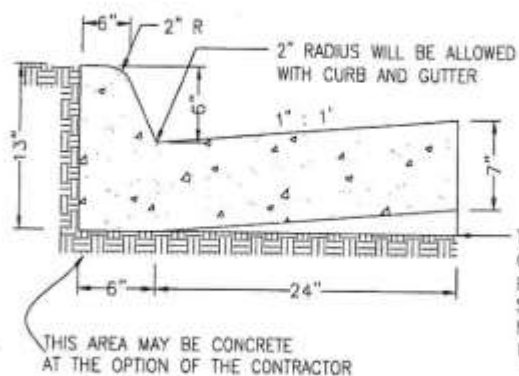

**STANDARD CURB & GUTTER**

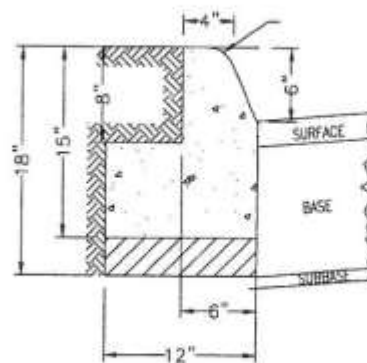

**ACCEPTABLE ALTERNATIVE TO CG-2**  
**IF CURB IS EXTRUDED**  
CURB AND GUTTER MAY BE EXTRUDED AT THE OPTION OF THIS CONTRACTOR AND APPROVAL OF THE INSPECTOR

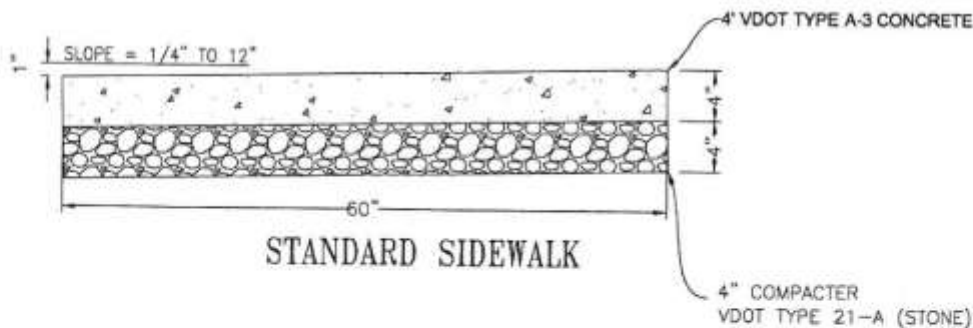

**STANDARD SIDEWALK**

REV. 7/21/2011

ALL MATERIALS AND CONSTRUCTION OF THIS DESIGN IN A RIGHT-OF-WAY SHALL CONFORM TO CURRENT VDOT ROAD AND BRIDGE SPECIFICATIONS AND VDOT ROAD AND BRIDGE STANDARDS

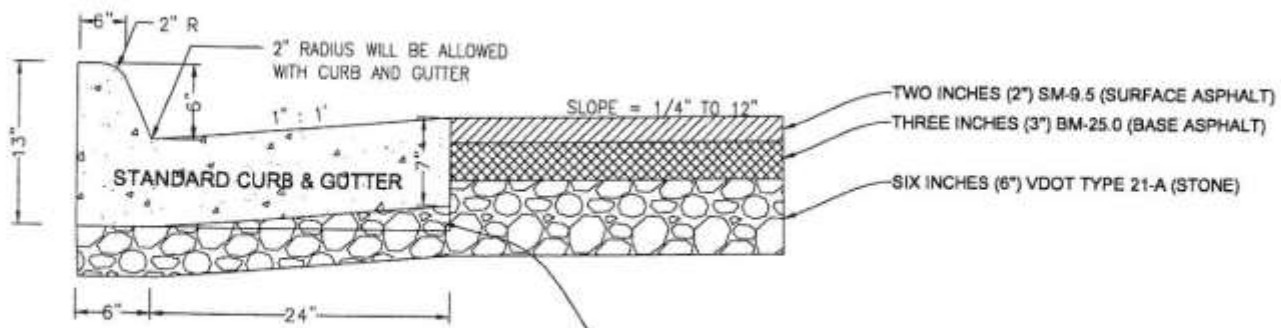
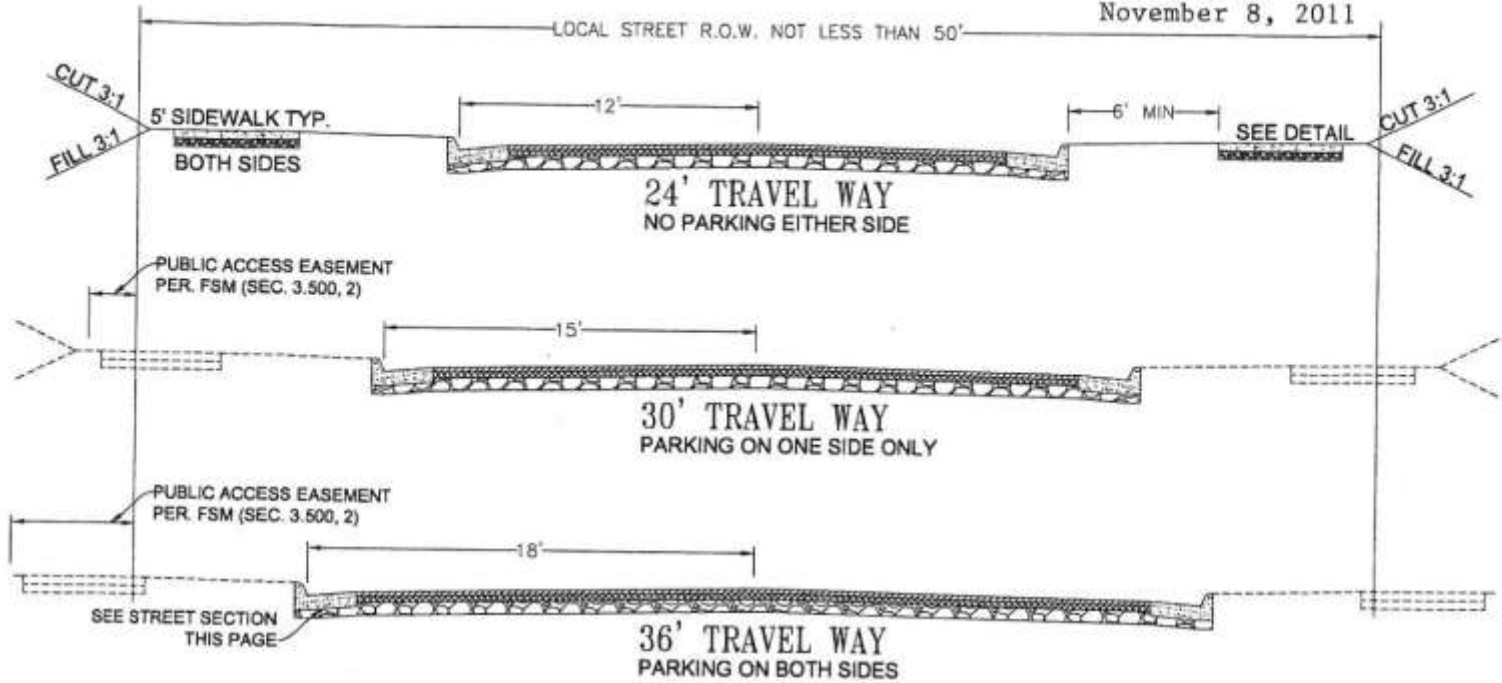

MINIMUM STREET SECTION

THE BOTTOM OF THE CURB AND GUTTER MAY BE CONSTRUCTED PARRALLEL TO THE SLOPE OF SUB SURFACE COURSES PROVIDED A MINIMUM DEPTH OF 7" IS MAINTAINED

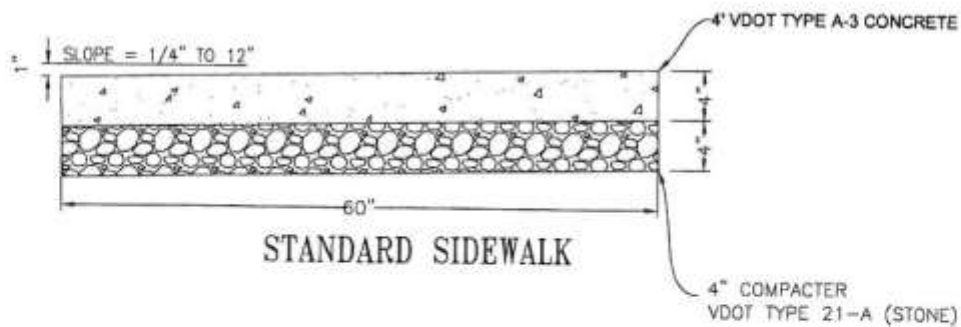

STANDARD SIDEWALK

REV. 7/21/2011

ALL MATERIALS AND CONSTRUCTION OF THIS DESIGN IN A RIGHT-OF-WAY SHALL CONFORM TO CURRENT VDOT ROAD AND BRIDGE SPECIFICATIONS AND VDOT ROAD AND BRIDGE STANDARDS

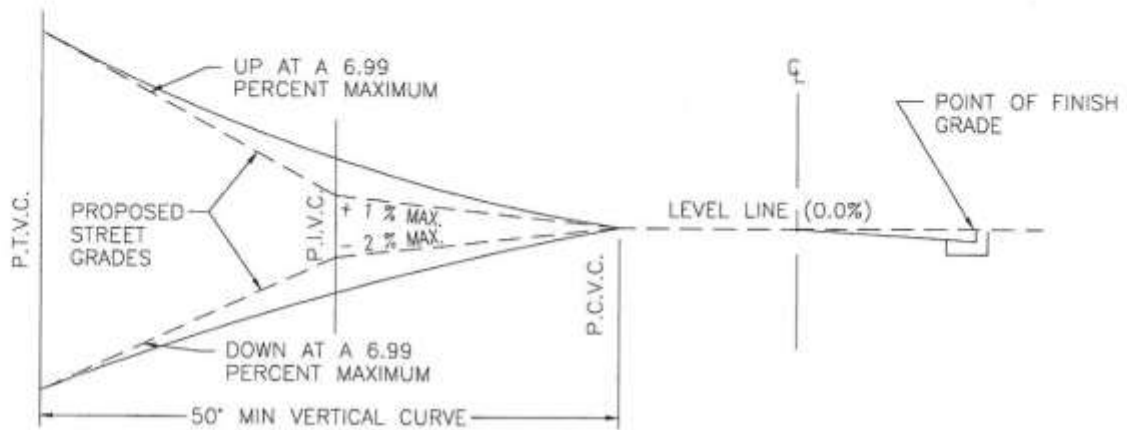
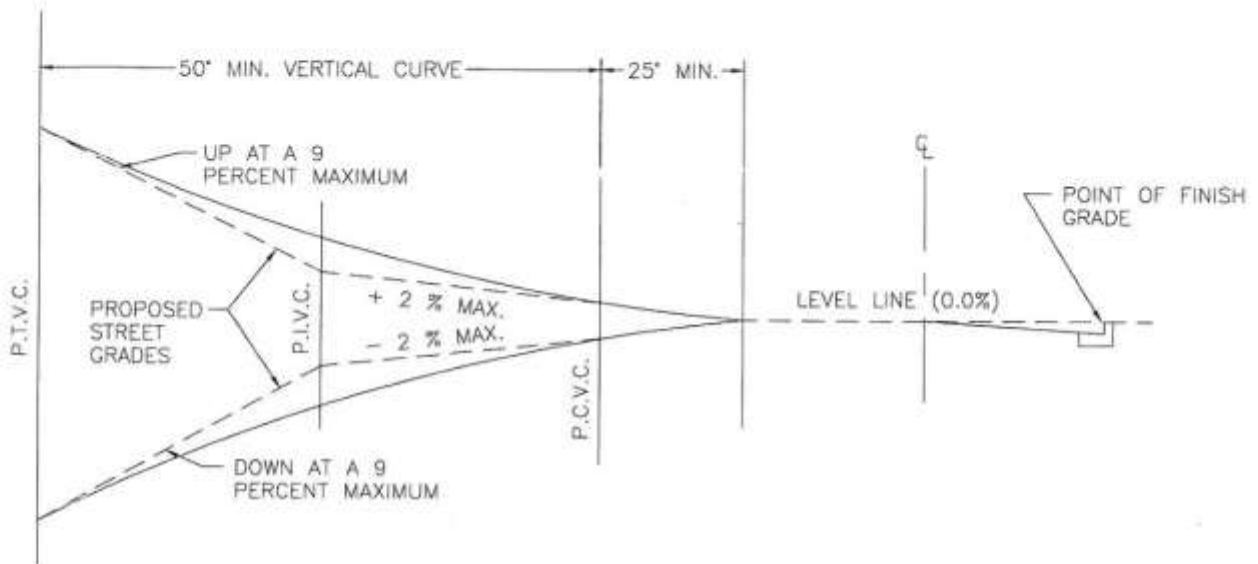

LANDING FOR GRADES LESS THAN 7%  
NOT TO SCALE

NOTES:

STREETS WITH CURB AND GUTER

1. BEGIN LANDING AT CURB LINE LOCATION AND TOP OF CURB ELEVATION.

STREETS WITHOUT CURB AND GUTER

1. BEGIN LANDING AT OUTSIDE EDGE OF PAVEMENT AND CENTERLINE ELEVATION.

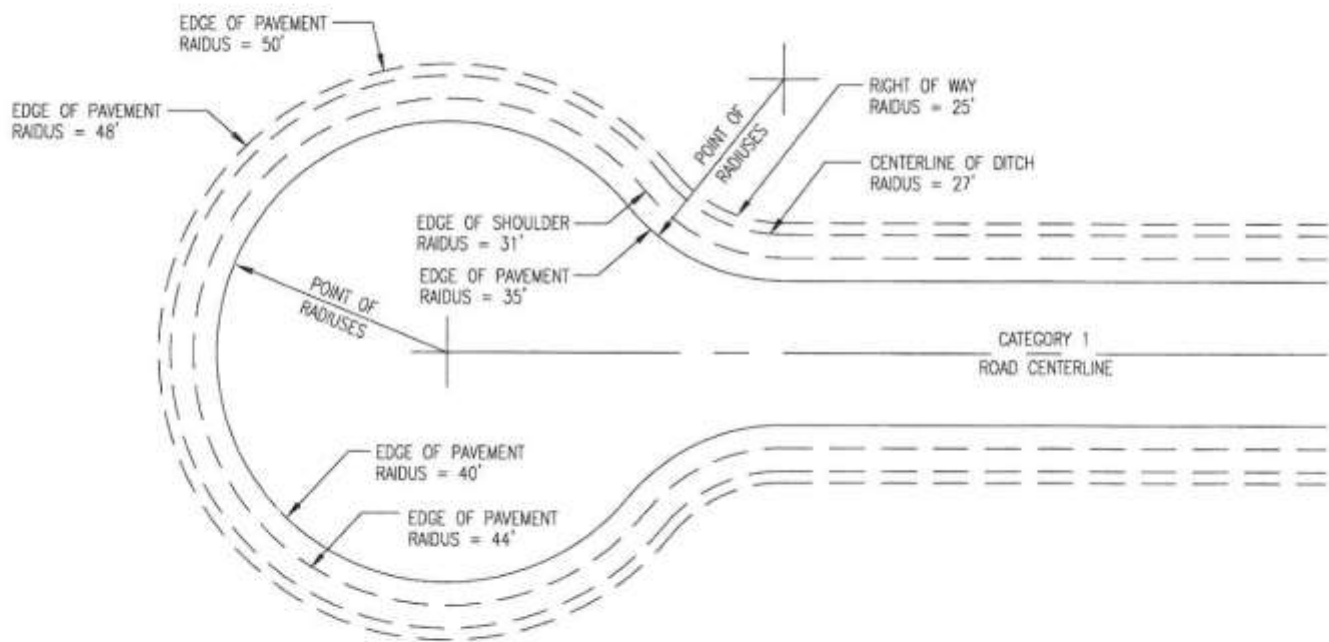
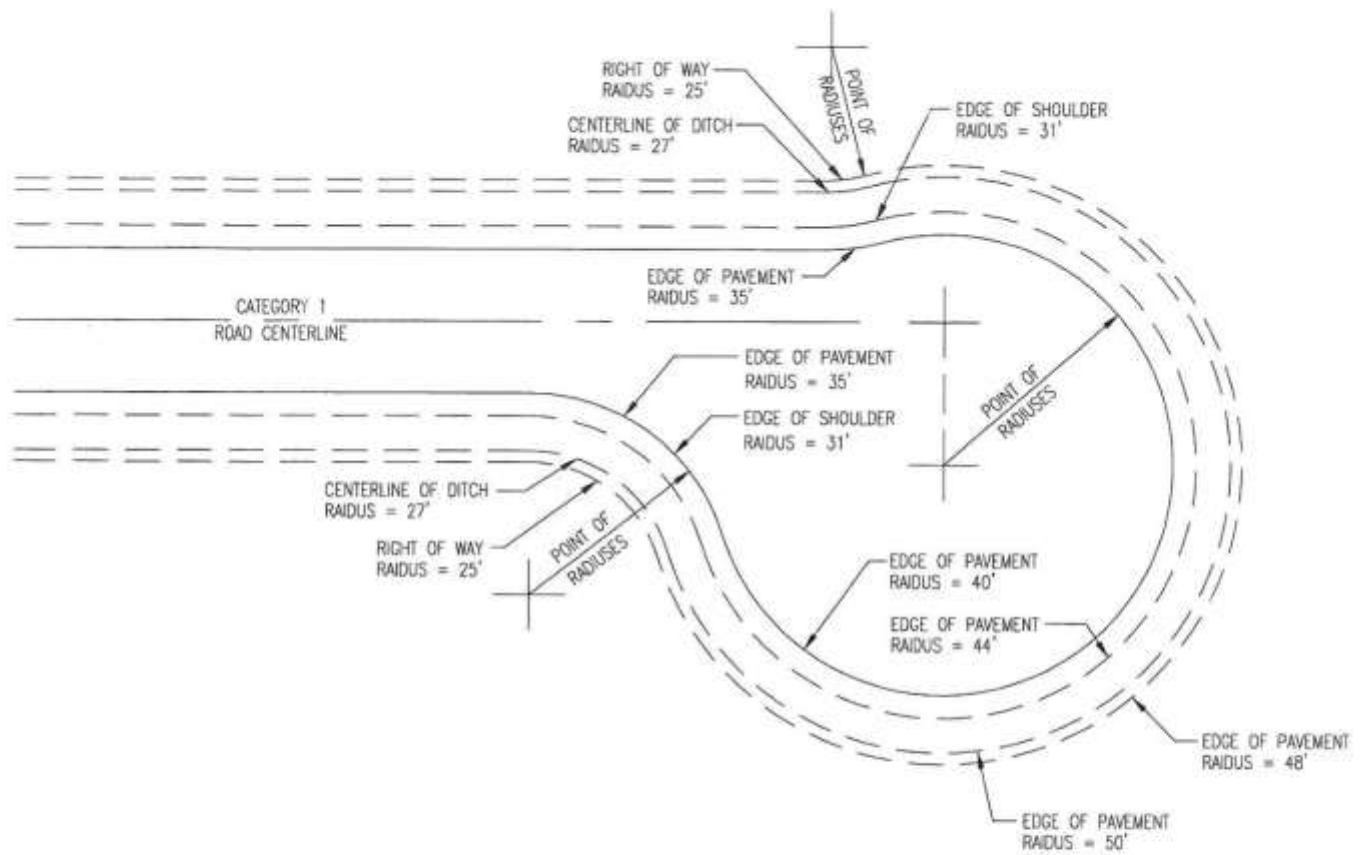

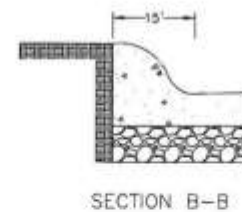
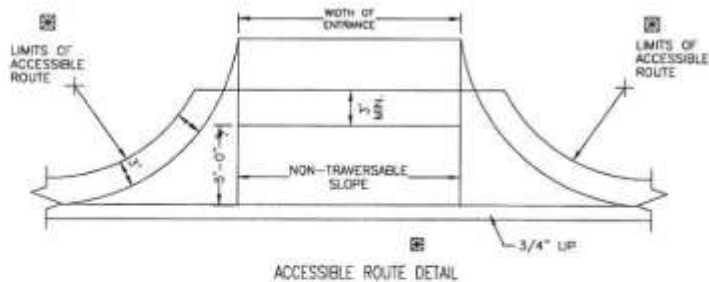
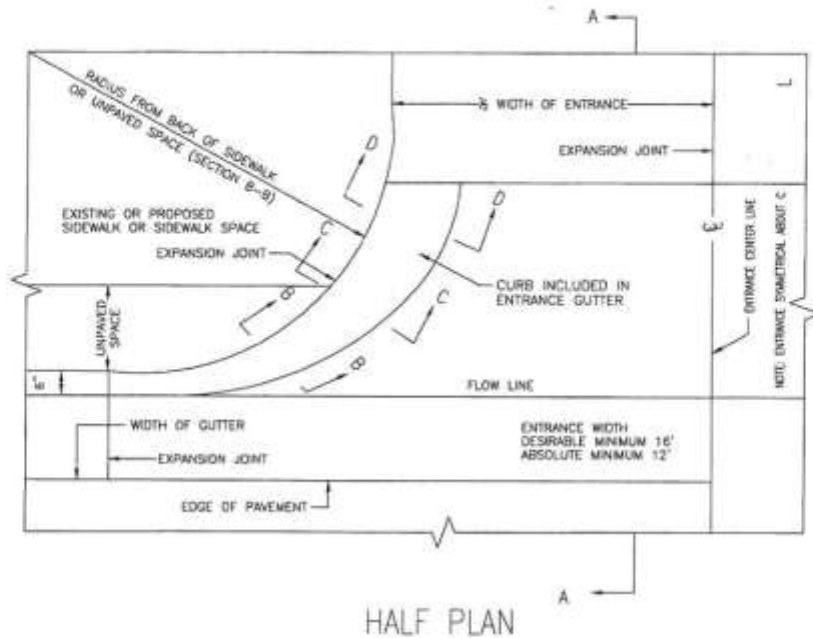

ADDITIONAL RIGHT OF WAY IS REQUIRED IF THE LIMITS OF ACCESSIBLE ROUTE \* EXTENDED BEYOND EXISTING OR PROPOSED VDOT RIGHT-OF-WAY

DETAIL TO BE USED WHEN THE COMBINED WIDTH OF UNPAVED SPACE AND SIDEWALKS SPACE IS LESS THAN 7''.

ACCESSIBLE ROUTES A CONTINUOUS UNOBSTRUCTED, STABLE, FIRM AND SLIP RESISTANT PATH CONNECTING ALL ACCESSIBLE ELEMENTS OF A FACILITY THAT CAN BE APPROACHED, ENTERED AND USED BY PEDESTRIANS.

IF ACCESSIBLE ROUTES ARE BEING PROVIDED, A MINIMUM 3' TRAVERSABLE WIDTH IS REQUIRED WITH A MAX. 2% CROSS SLOPES.

HALF PLAN

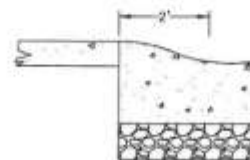

SECTION C-C

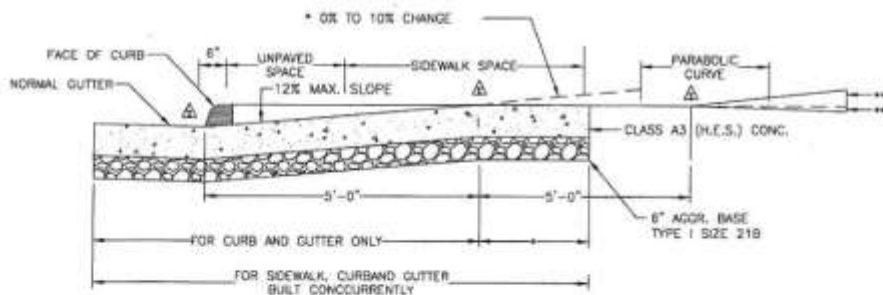

POINT OF CURVE  
 12% MAXIMUM INCREASE IN SLOPE AT MINIMUM 10' INTERVALS  
 3% MAXIMUM DECREASE IN SLOPE FOR THE FIRST 10' INTERVAL, AND  
 8% MAXIMUM DECREASE FOR SUCCEEDING MINIMUM 10' INTERVALS

SECTION A-A

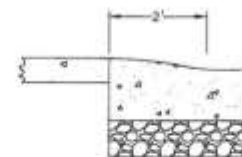

SECTION D-D

NOTE:  
 WHEN USED IN CONJUNCTION WITH STANDARD CG-3 OR CG-7 THE CURB FACE ON THIS STANDARD IS TO BE ADJUSTED TO MATCH THE MOUNTABLE CURB CONFIGURATION.

STANDARD VDOT CG-9D REV. 1/04

TOWN OF CULPEPER  
 VIRGINIA

STANDARD DRIVEWAY  
 ENTRANCE

3.6

LETTER SYMBOL

DIMENSIONS

A	AS DETERMINED BY THE TOWN ENGINEER
B	150' MINIMUM
C	200' DESIRABLE MINIMUM FOR ENTRANCE TO MAJOR SHOPPING CENTER AS DETERMINED BY THE TOWN ENGINEER
F	30' MINIMUM
G	EQUAL WIDTH OF ONE APPROACH LANE WITH A MINIMUM OF 10'
I	25' MINIMUM
K	4' MAXIMUM
L	6" (STANDARD CURBING) 4" (ST'D. MOUNTABLE CURBING)
D	12.5' MINIMUM
P	25' MINIMUM 50' DESIRABLE MINIMUM
U	12.5' MINIMUM 25' DESIRABLE MINIMUM
W	30' MINIMUM 50' MAXIMUM OR AS DETERMINED BY TOWN ENGINEER
Y	45' MINIMUM 90' DESIRABLE
	CURB-CUT RAMP

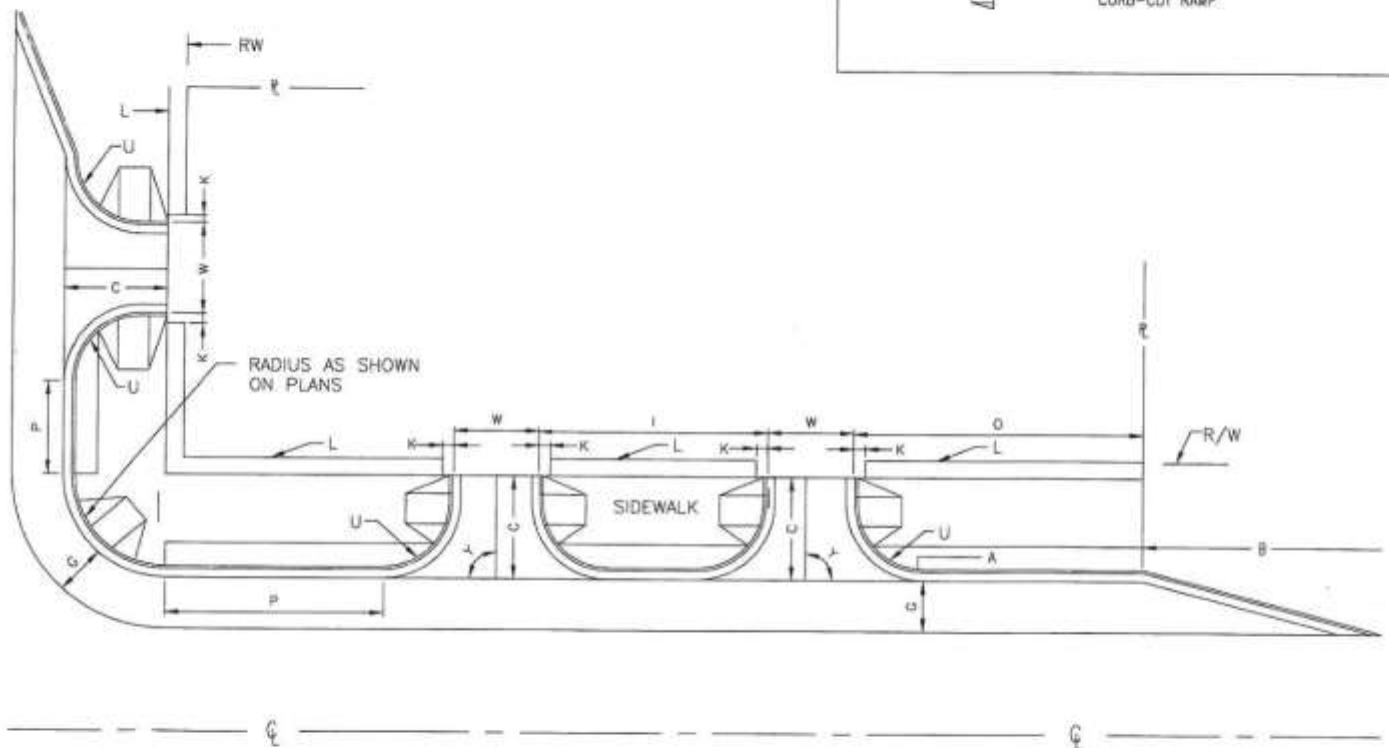



COLORS: CIRCLE & DIAGONAL -RED 3M® SERIES 3800 (ENGINEERING GRADE) SHEETING  
 LETTER "P", TEXT, BORDER -BLACK  
 BACKGROUND -WHITE 3M® SERIES 3800 (ENGINEERING GRADE) SHEETING

TOWN OF CULPEPER,  
 VIRGINIA

"NO PARKING"  
 SIGN DETAIL

3.7.1



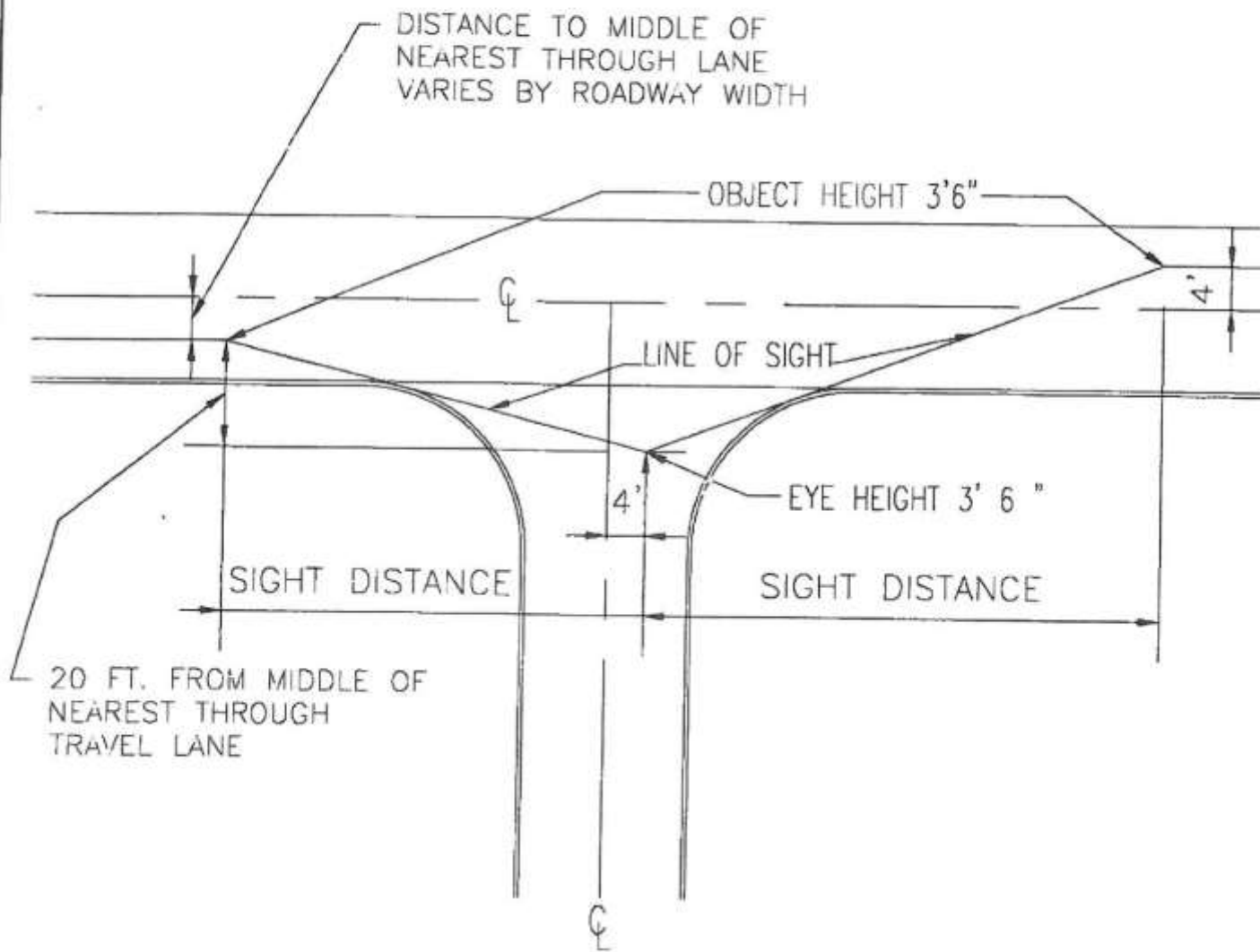

NOT TO SCALE

SIGHT DISTANCE

DESIGN SPEED	25 MPH	30 MPH	35 MPH	40 MPH	45 MPH
2 OR 3 LANE ROAD	280 ft.	335 ft.	390 ft.	445 ft.	500 ft.
4 LANE MAJOR ROAD UNDIVIDED	295 ft.	355 ft.	415 ft.	475 ft.	530 ft.
4 LANE MAJOR ROAD DIVIDED	325 ft.	390 ft.	455 ft.	475 ft.	580 ft.

PAGE 84

**TOWN OF CULPEPER  
VIRGINIA**

**ENTRANCE SIGHT  
DISTANCE**

REVISED 2/10

**3.8**

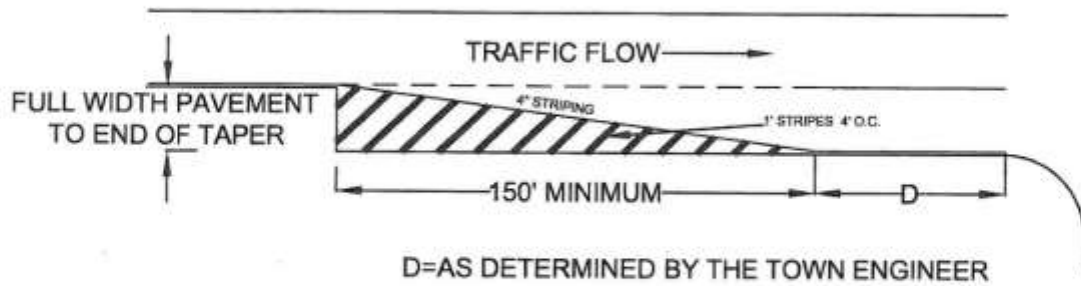

## RIGHT TURN LANE WITH TAPER

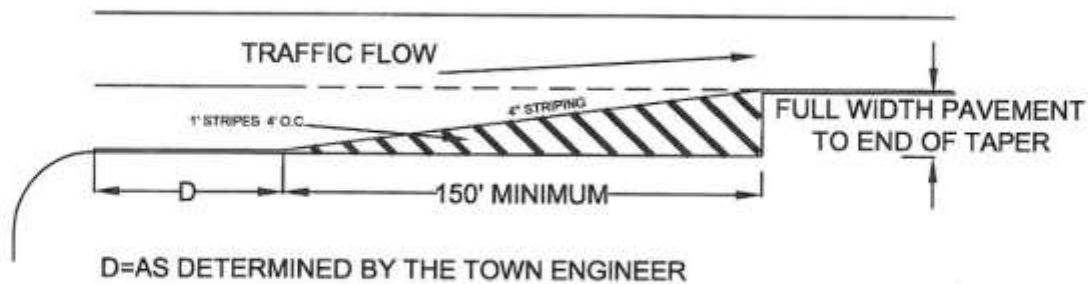

## ACCELERATION LANE



**Street Name Signs**

- a. Size  
6" x 27"
- b. Colors  
PMS 216 red  
Reflective White
- c. Materials  
Silkscreened High Intensity Reflective Sheeting mounted on aluminum sign base. Painted back.
- d. Type Size and Style  
Serif - Garamond typeface or similar, condensed, small cap.  
Loose Kerning
- e. Logo  
• Stylized figure-ground image of district. Design to be developed with either commercial or residential image as shown above.
- f. Mounting System  
Mount to existing poles or new round poles, painted black.

**TOWN OF CULPEPER  
VIRGINIA**

**STREET NAME SIGN**

**5.1**

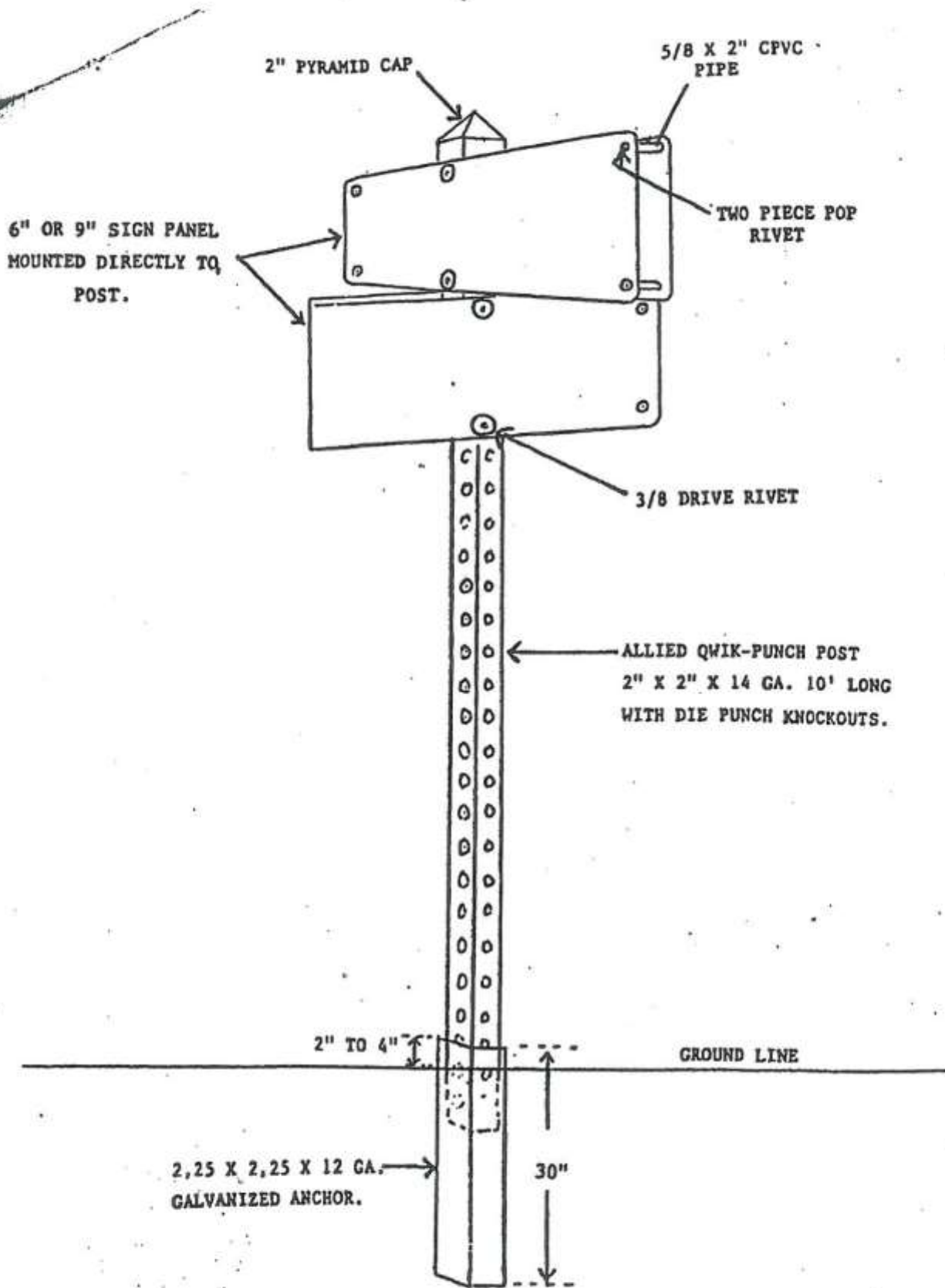

TOWN OF CULPEPER	SIGN INSTALLATION DIRECT MOUNT METHOD	5.1a
---------------------	--	------

FOUNDATION DETAILS

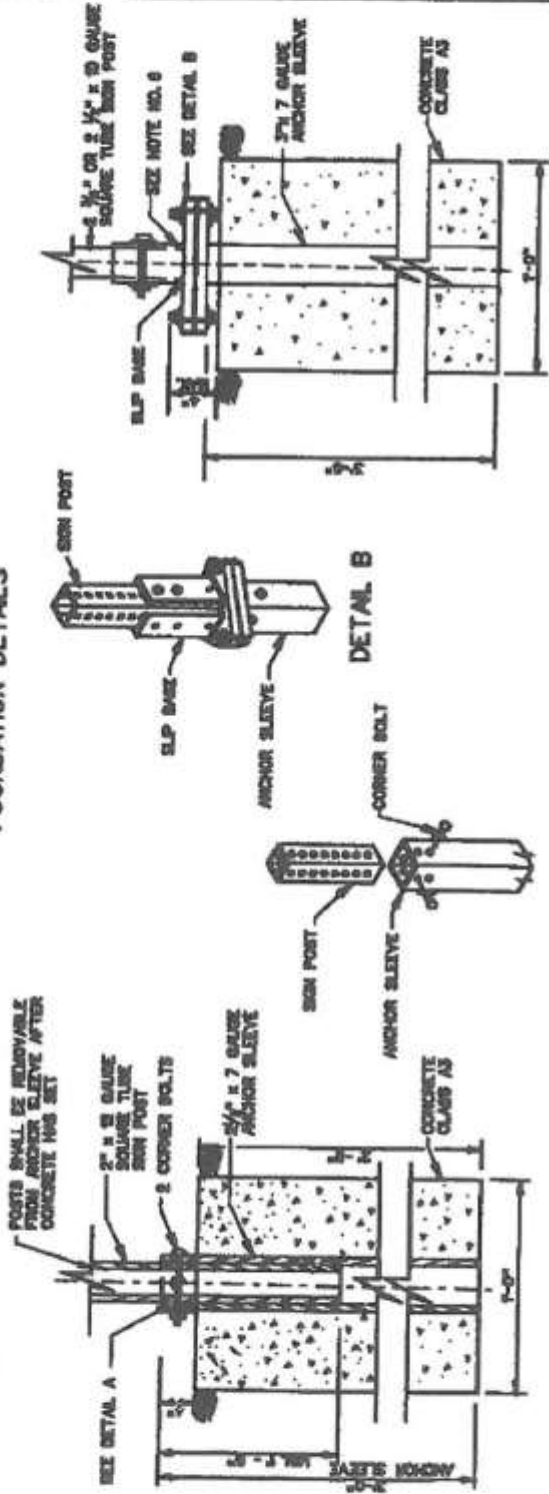

SIGN POST TO BE INSTALLED ON SLIP BASE IN ACCORDANCE WITH MANUFACTURER'S RECOMMENDATIONS

SIGN PANEL ATTACHMENT DETAILS



NOTES:

NYLON WASHER SHALL BE 1/4" THICK MINIMUM WITH AN OUTSIDE DIAMETER OF 1" AND AN INSIDE DIAMETER OF 3/4".

TOP OF SIGN PANEL SHALL BE FLUSH WITH THE TOP OF THE POST.

SIGN PANEL DESIGN SHALL BE IN ACCORDANCE WITH STANDARD SPD-5.

CORNER BOLT



CORNER BOLTS SHALL BE 3/8" DIA. CORNER BOLT WITH SERRATED FLANGE NUT.

CORNER BOLTS SHALL BE USED FOR ATTACHING THE SQUARE TUBE SIGN POST TO THE ANCHOR SLEEVE OR SLIP BASE.

VDOT

ROAD AND BRIDGE STANDARDS

REVISION DATE

SQUARE TUBE SIGN POST

Town of Culpeper Street Sign Post

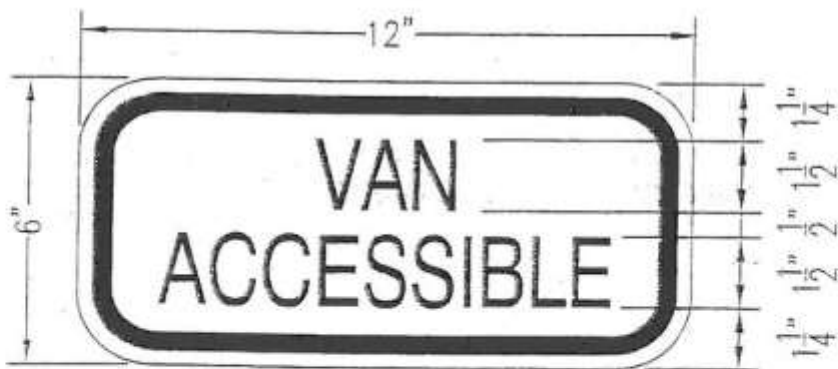



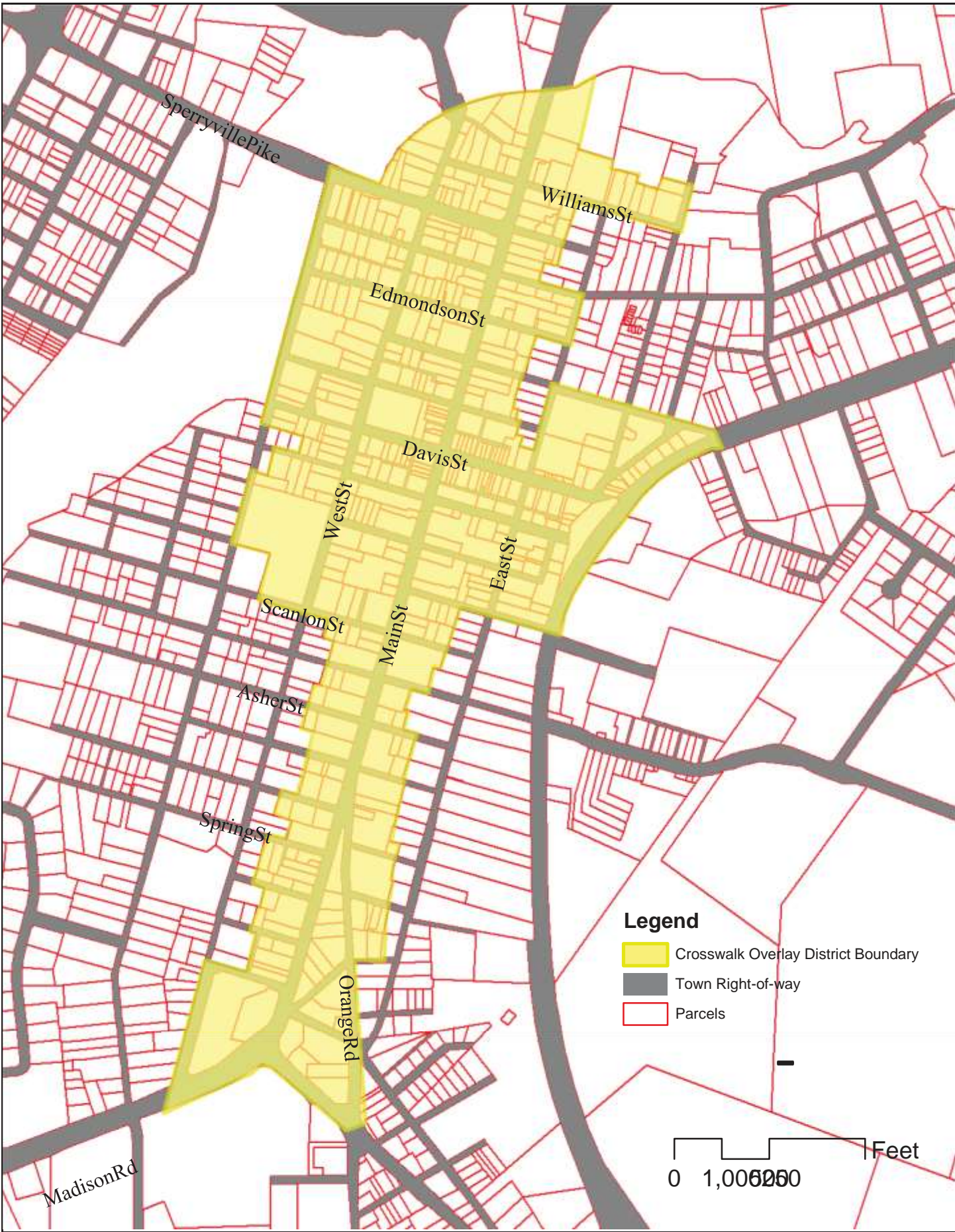



Town of Culpeper Virginia	CROSSWALK OVERLAY BOUNDARY	5.4
---------------------------	----------------------------	-----

## On-Street Bikeway Examples

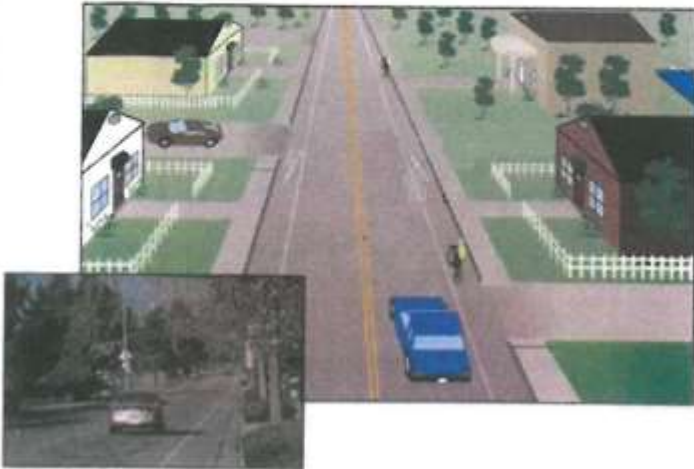

A two-lane collector street in a residential neighborhood



This example utilizes lane widths, speed, and volume to accommodate motorists and bicyclists.

## Bump-outs and Traffic Calming Examples



This example "chokes" the street entrance to a nine-foot travel lane.



This bump-out reduced turning speeds by 6-8 MPH and reduced the pedestrian crossing distance and time exposed to traffic

# Belson Gemini-Bel Bike Racks

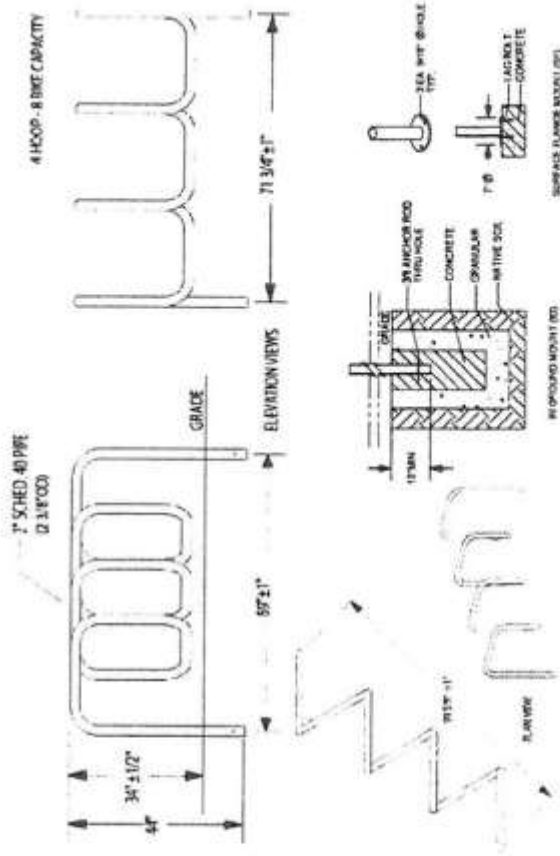
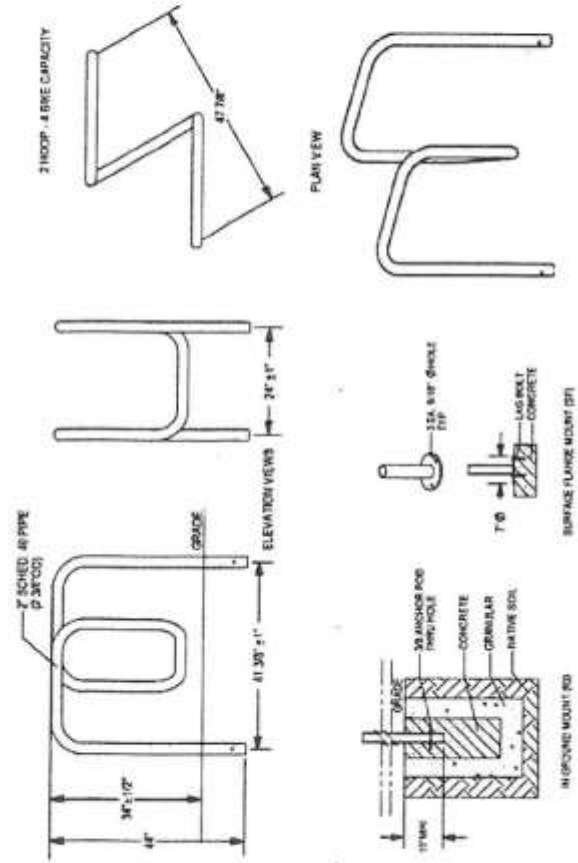
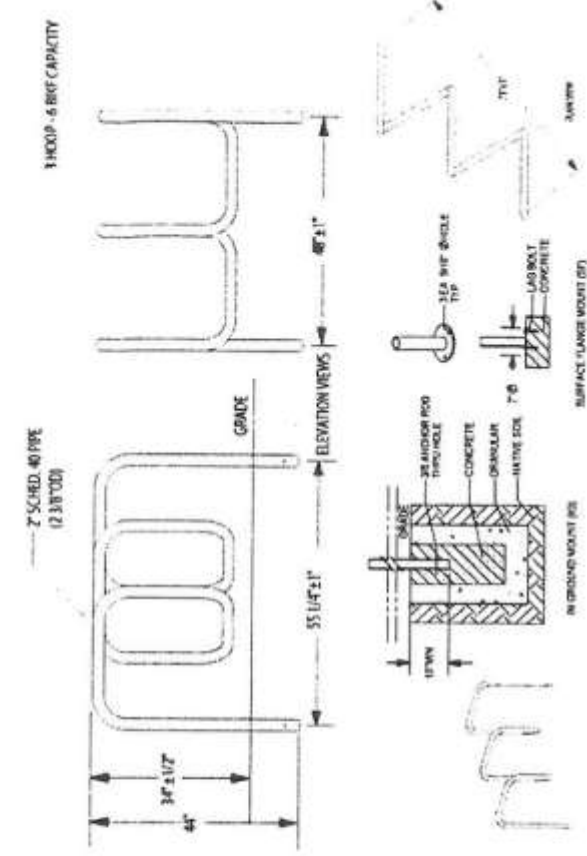

## 2, 3, and 4-Hoop Surface and Ground-Mounted Bike Racks

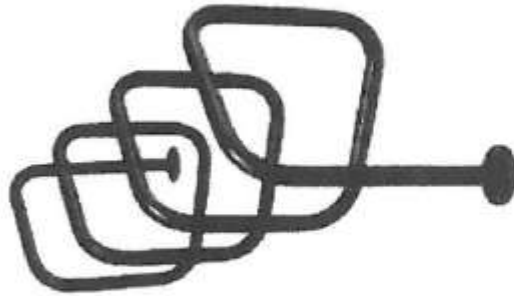

Belson Model G8-P-SF  
4 Hoop Bike Rack

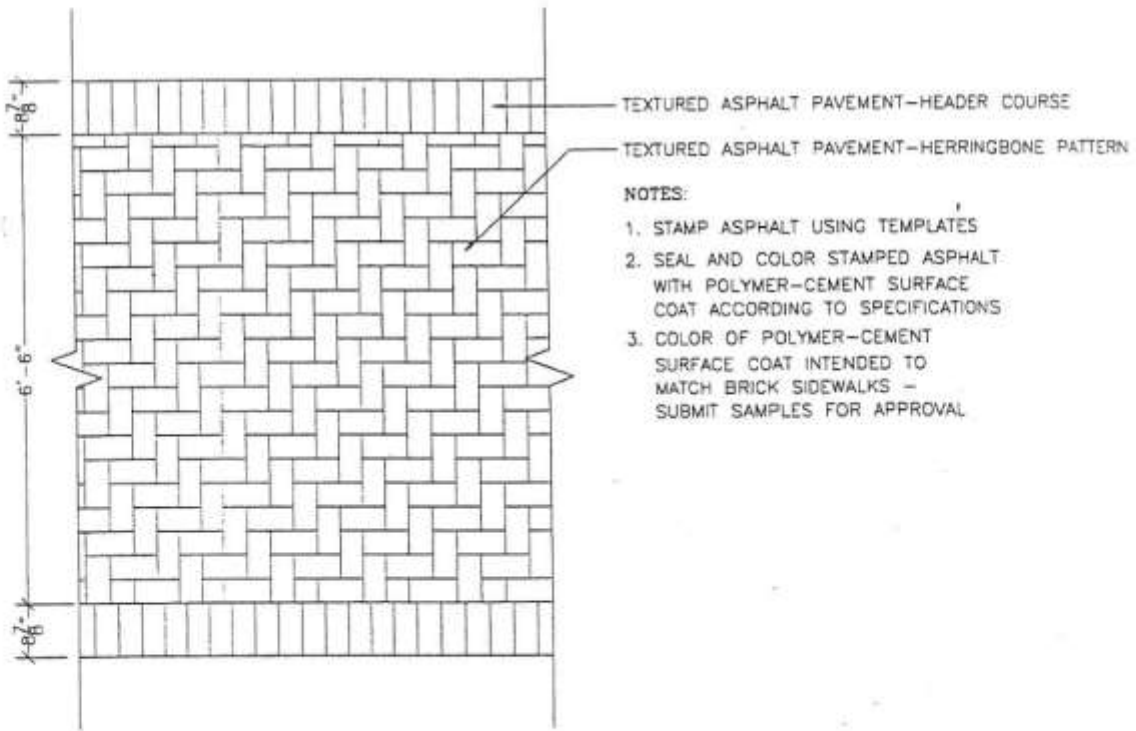

GENERAL NOTES:

- ALL MATERIALS AND CONSTRUCTION OF THIS DESIGN IN A RIGHT-OF-WAY SHALL CONFORM TO CURRENT VDOT ROAD AND BRIDGE SPECIFICATIONS AND VDOT ROAD AND BRIDGE STANDARDS
- ALTERNATE PATTERNS MAY BE USED AS LONG AS APPLIED CONSISTENTLY THROUGHOUT THE DEVELOPMENT

STREET TREE LANDSCAPING  
REQUIREMENTS REFER  
TO SECTION 5.100 (B)

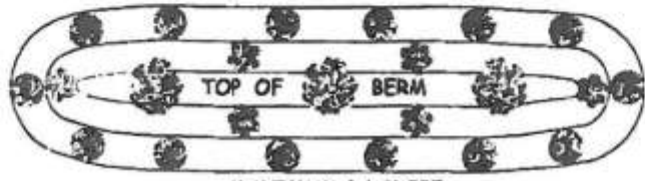
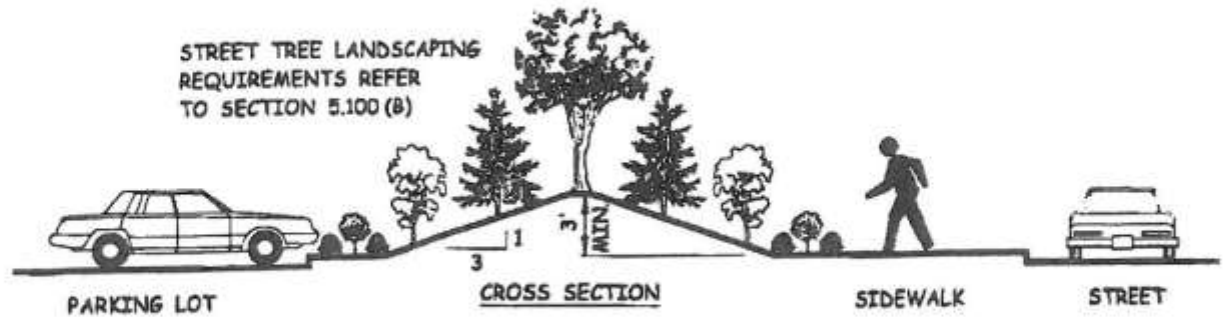

MAXIMUM 3:1 SLOPE  
TOP VIEW

EARTH BERM AND  
FRONTAGE LANDSCAPING

SCREENING TREE LANDSCAPING  
REQUIREMENTS REFER  
TO SECTION 5.100 (B)

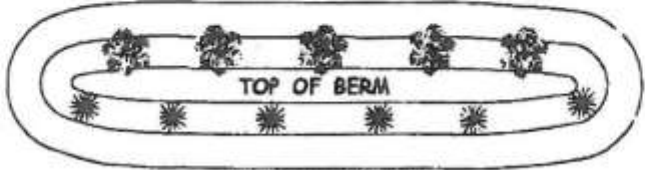
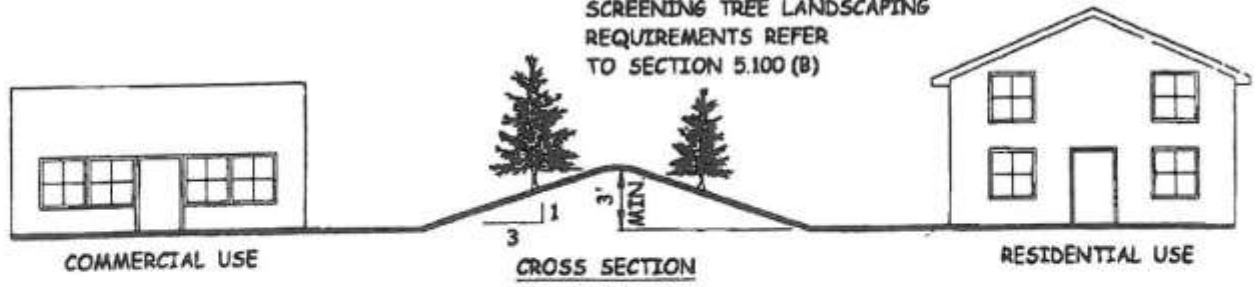

MAXIMUM 3:1 SLOPE  
TOP VIEW

EARTH BERM AND  
PLANTED BUFFER  
10 - 20 FEET

SCREENING TREE LANDSCAPING  
REQUIREMENTS REFER  
TO SECTION 5.100 (B)

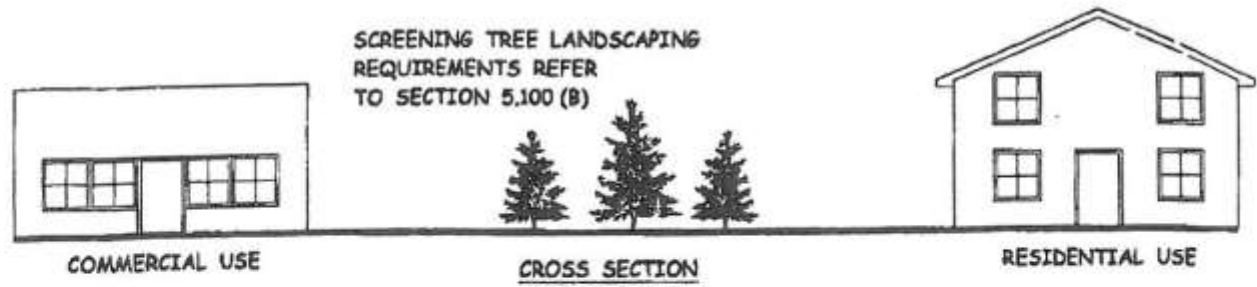

PLANTED BUFFER  
NO EARTH BERM

# Standard Duty Pole

SUBMITTAL DRAWING

- APPROVED
- APPROVED AS NOTED
- DISAPPROVED

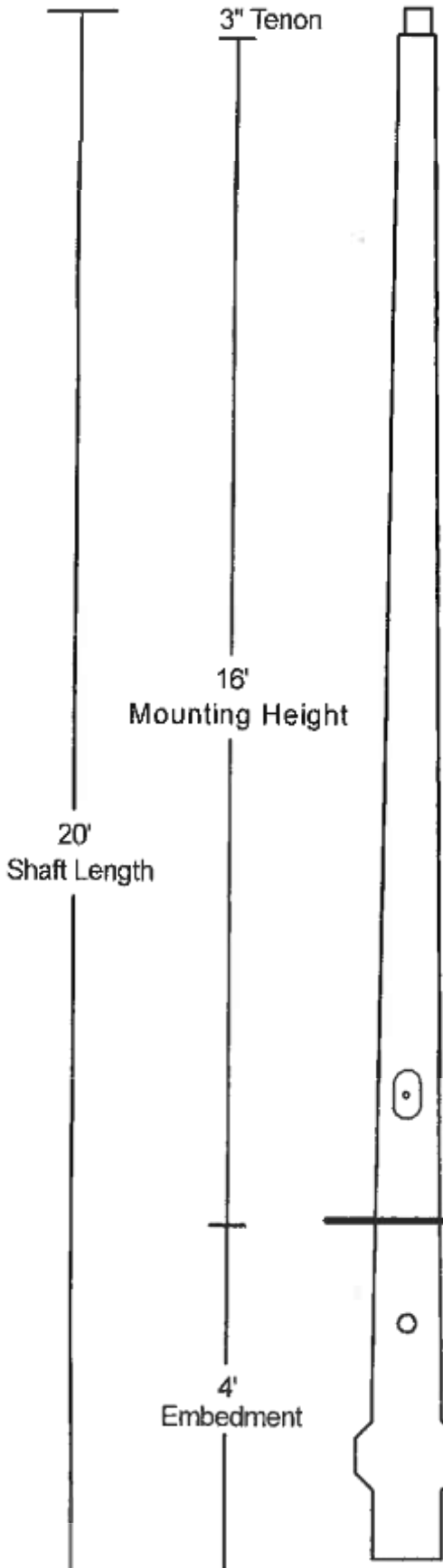

## POLE SPECIFICATIONS

FILAMENT WOUND TAPERED COMPOSITE SHAFT CONSISTING OF CONTINUOUS FIBERGLASS ROVING COMBINED WITH THERMOSETTING POLYESTER RESIN WOUND IN LOW-ANGLE HELICALS AND HIGH-ANGLE HOOPS PROVIDING MAXIMUM RESISTANCE TO DEFLECTION AND SHEAR (US PATENT #6,367,225B1)

COLOR: BLACK  
FINISH: SMOOTH

MAXIMUM FIXTURE EPA = 4.6  
MAXIMUM FIXTURE WEIGHT = 100 LBS  
MAXIMUM WIND VELOCITY = 80 MPH w 1.3 GUST

DIRECT BURIAL POLE ASTM 4923 CLASS 1 (POLE TOP DEFLECTION SHALL NOT EXCEED 15% OF THE ABOVE GROUND HEIGHT @ MAX WIND LOADING AND MAX FIXTURE WEIGHT) DESIGN CRITERIA PER AASHTO LTS-2-S-1994 AND ANSI C136.20-1990 WITH A MIN SAFETY FACTOR OF 2.0

CATALOG # WPODS20ASDS3

BRIDGEWELL RESOURCES  
4765 SPOTSWOOD TRAIL  
PENN LAIRD VA 22846

ph 800-851-0104 fax 540-432-2376

**DESCRIPTION**

The Acorn tastefully compliments roadways, parks and residential roadways.

Catalog #	ANE 10SR 2551S	Type	
Project		Date	
Comments			
Prepared by			

**SPECIFICATION FEATURES**

**Construction**

Cast aluminum housing. Standard with two position terminal block. Standard color is black. Other finish colors available. Consult your Streetworks Representative. 1" ANSI wattage/source label.

**Electrical**

**SOCKET:** Mogul-base socket for 50W through 150W High Pressure Sodium and 175W and 250W Metal Halide; 50W through 150W Metal Halide is medium-base socket. All sockets are 4KV pulse rated.  
**BALLAST:** Easily accessible, tilt-back power module. Standard plug-in starter when applicable.  
**PHOTOCONTROL:** Optional NEMA twistlock photocontrol receptacle also available.

**Optical**

**GLOBE:** 8" textured polycarbonate globe is standard. Optional globes include a 9" polycarbonate, 8" and 9" milk white, and 8" and 9" acrylic. (Optional internal Type III refractor available).

**Mounting**

Post-top mount fits 3" tenons. Secures with three (3) square headed 1-1/4" polymer coated mounting bolts.

**Finish**

Standard polyester powder coat finish in black. Standard color is black. Optional bronze, white, grey, hartford green, dark platinum and graphite metallic finishes are available.



**ANE  
ACORN**

50 - 250W

Pulse Start Metal Halide  
High Pressure Sodium  
Metal Halide

DECORATIVE LUMINAIRE

**DIMENSIONS**

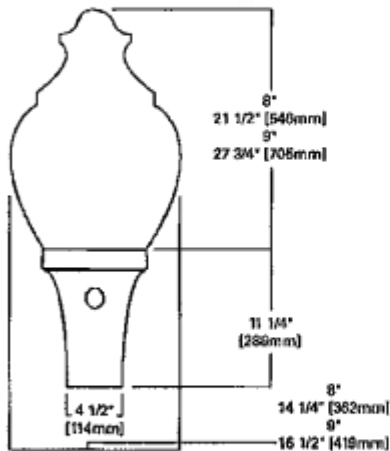

**TILT-BACK POWER MODULE**

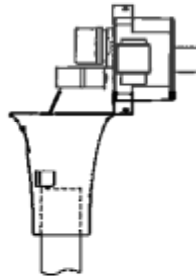

**FINIAL OPTIONS (PAINTED TO MATCH HOUSING)**

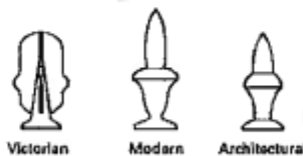

EPA  
Effective Projected Area:  
1.7 Square Feet

SHIPPING DATA  
Approximate Net Weight:  
30 lbs. (14 kgs.)



ADW082049  
2010-03-11 13:16:21

PHOTOMETRICS (Complete IES files available at [www.cooperlighting.com](http://www.cooperlighting.com))

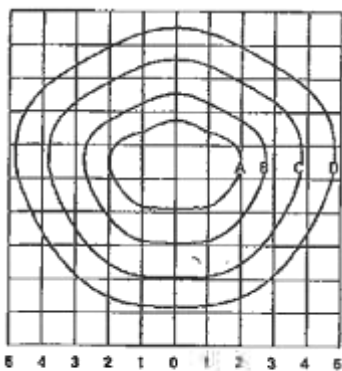

**ANE15S33.IES**  
150-Watt HPS  
16,000-Lumen Lamp  
Type III

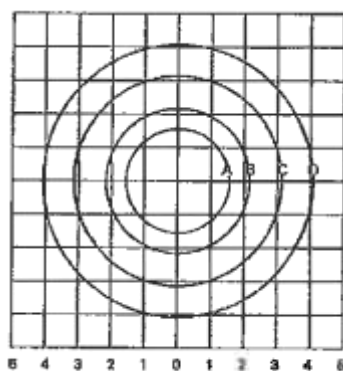

**ANE15S55.IES**  
150-Watt HPS  
16,000-Lumen Lamp  
Type V

**FOOTCANDLE TABLE**

Select mounting height and read across for footcandle values of each isofootcandle line. Distance in units of mounting height.

Mounting Height	Footcandle Values for Isofootcandle Lines			
	A	B	C	D
<b>ANE15S33.IES</b>				
12'	1.36	0.68	0.34	0.13
14'	1.00	0.50	0.25	0.10
16'	0.76	0.38	0.19	0.07
<b>ANE15S55.IES</b>				
12'	1.36	0.68	0.34	0.13
14'	1.00	0.50	0.25	0.10
16'	0.76	0.38	0.19	0.07

**ORDERING INFORMATION**

Sample Number: ANE50GR2654

<p><b>Product Family</b> ANE=Acorn</p> <p><b>Lamp Wattage</b> Probe Start Metal Halide</p> <p>70=70W 10=100W 15=150W 17=175W 25=250W</p> <p><b>High Pressure Sodium</b></p> <p>50=50W<sup>2</sup> 70=70W 10=100W 15=150W 20=200W 25=250W<sup>2</sup></p> <p><b>M.I. (Probe Start)</b><sup>3</sup></p> <p>17=175W 25=250W</p>	<p><b>Lamp Type</b><sup>4</sup></p> <p>P=Probe Start Metal Halide S=High Pressure Sodium M=Metal Halide</p> <p><b>Ballast Type</b><sup>5</sup></p> <p>H=Reac. HPF K=10KV CWA<sup>4</sup> N=HL.Reac./NPF P=H. Reac./HPF R=H.Reac./NPF<sup>4</sup> W=CWA</p>	<p><b>Voltage</b><sup>1</sup></p> <p>2=120V 0=208V 4=240V 7=277V 8=480V</p> <p>F=120/240 wired 120V W=Multi-Tap wired 120V G=120/240 wired 240V V=Multi-Tap wired 240V N=Multi-Tap wired 277V</p> <p><b>Distribution</b></p> <p>33=Type III 55=Type V</p>	<p><b>Options</b></p> <p>CEC=California Title 20 Compliant Ballast (Applies to 175-200W Pulse Start MH only)</p> <p>1=Single Fuse (120, 277 or 347V) 2=Double Fuse, (208, 240, or 480V) 4=NEMA Twistlock Photocontrol Receptacle 8=Internal Button<sup>6</sup> Photocontrol</p> <p>WH=White BZ=Bronze AP=Grey H=Hartford Green DJ=Dark Platinum A=Acrylic Globe B=Acrylic Globe 9" g=9" Globe M=Milk White Globe S=Screw Secure Power Module N=NEMA Ballast Bracket<sup>6</sup> F=Finish U=UL/CSA Listed</p>	<p><b>Accessories</b></p> <p>AA1000=House Side Shield (9" Globe) AA1001=House Side Shield (9" Globe)</p>
--	--	---	--	--

- Notes: 1 Refer to the technical section for lamp/ballast voltage compatibility.  
2 Available in 120V only.  
3 Probe Start Metal Halide available for non-US markets only (175-250W).  
4 Available 50-150W, 120/240 or single voltage only.  
5 Specify single voltage.  
6 Available in Reactor HPF and NPF. For HL Reactance or CWA availability consult your Streetworks Representative.



Replacement diagram 6.3. Lighting pole diagram.

AGENCY: Bradley Electro  
PROJECT: Town of Culpepper  
QUOTE#:

**POLE**

Model: CF50  
Top Dia: 5.2"  
Taper: 0.14"/ft  
Construction: Spun Cast Fiberglass Composite  
Anchor Base: Plate- 1/2"x15.5" RND Hot Rolled  
Steel ASTM A36 with slots for 3/4" bolts  
Bolt Circle: 13"  
Tenon: 3" OD 3" Exposed length .188" wall  
6061-T6 Alum  
Paint: UV & Cleaning chemical resistant  
Color: Black  
Option: RC  
MAX Attachment Weight: 100 lbs  
MAX Attachment EPA: 20.1 @ 90 mph ANSI  
Pole Weight: 70 lbs approx.

**BASE COVER**

Model: D25M/2  
Style: 2-Piece Clamshell  
Material: Elastomeric Urethane  
Color: Black  
Height: 19.13"  
Width: 19.25"  
Weight: 31.6 lbs approx

**ANCHOR BASE DETAIL**

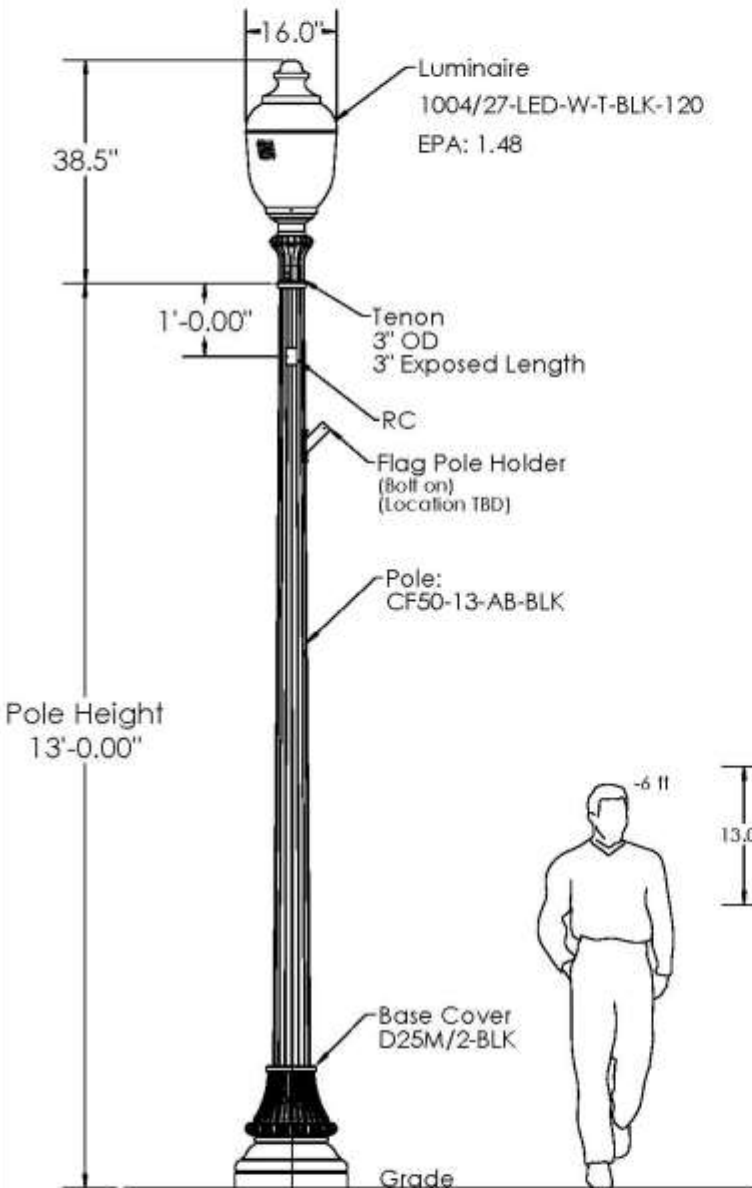
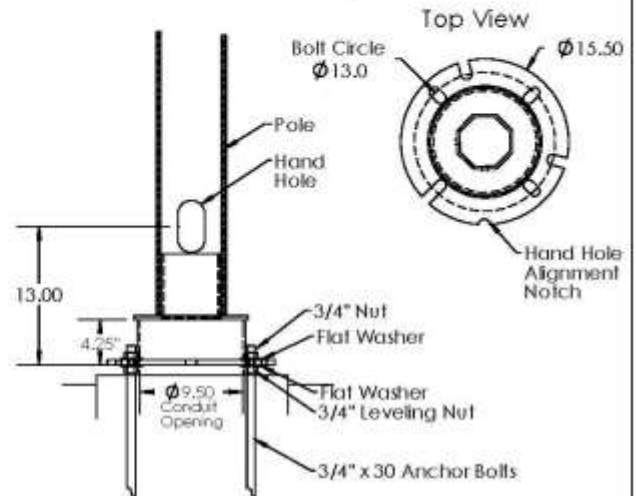

**WHATLEY, INC.** A Valmont Company

19845 US Highway 76  
Newberry, SC, 29108  
phone: (877) 959-7678  
fax: (803) 276-8940  
web: www.whatley.com

REV	DESCRIPTION	DATE
A	Added RC Option	8/21/15
B	Revised height from 18 to 13	8/27/15
C	Revised Anchor Base	7/21/16
D	Added Dimensions	7/21/16
E	Added Flag Pole Holder	7/22/16

PART NO. CF50-D25M/2-13-AB-BLK-30-30-RC DESCRIPTION: Pole Assembly

SCALE: 1:30 SIZE: A REV. E

MATERIAL: Noted  
FINISH: Smooth  
**DO NOT SCALE DRAWING**

DOCUMENTATION	INITIAL	DATE
DRAWN	JTC	8/18/15
QUOTE REQUEST		
TOOLING REQUEST		
FIRST ARTICLE REQUEST		
FIRST ARTICLE INSPECTION		
PRODUCTION RELEASE		

UNLESS OTHERWISE NOTED:  
DIMENSIONS ARE IN INCHES  
TOLERANCES:  
DECIMAL XXX ± .03  
DECIMAL XXXX ± .010  
ANGLE ± 1/2

**PROPRIETARY AND CONFIDENTIAL**  
THE INFORMATION CONTAINED IN THIS DRAWING IS THE SOLE PROPERTY OF WHATLEY, INC. ANY REPRODUCTION IN PART OR AS A WHOLE WITHOUT THE WRITTEN PERMISSION OF WHATLEY, INC. IS PROHIBITED.

**MINIMUM CLEAR SPACE REQUIREMENTS**

- A. 7'0" FROM FINISHED GRADE TO LOWEST OBSTRUCTION.
- B. 36" MEASURED FROM FACE OF METER.
- C. 36" WIDE UNOBSTRUCTED TRAVEL WAY.
- D. 2" ON BOTH SIDES OF METER TO ANY OPENING ON THE SAME PLAIN INTO THE BUILDING OR SIDE OBSTRUCTION.
- E. 6' ± 6" FROM FINISHED GRADE

**SUPPORT REQUIREMENTS**

- \* METERBASE SHALL BE ATTACHED TO DWELLING WITH 4 SCREWS (MINIMUM #8, 1-1/4" IN LENGTH)
- \* DRYWALL SCREWS ARE NOT ACCEPTABLE
- \* METERBASE SHALL BE ATTACHED TO PLYWOOD, SOLID STUD, BRICK, BLOCK, OR CONCRETE BACKING SUBJECT TO NOVEC APPROVAL. ANCHORS MUST BE USED WHEN INSTALLING IN MASONRY OR CONCRETE.

METER BASES ON SINGLE FAMILY HOMES ON LOTS SMALLER THAN 2.5 ACRES, MUST BE WITHIN 5' OF THE FRONT CORNER OF THE HOUSE OR THE CUSTOMER SHALL BE REQUIRED TO INSTALL CONDUIT. THE CONDUIT MUST EXTEND 5' BEYOND THE HOUSE TO THE STREET SIDE OR SOURCE AS DESIGNATED BY NOVEC.  
(SEE BG-MB2 AND BG-SC1)

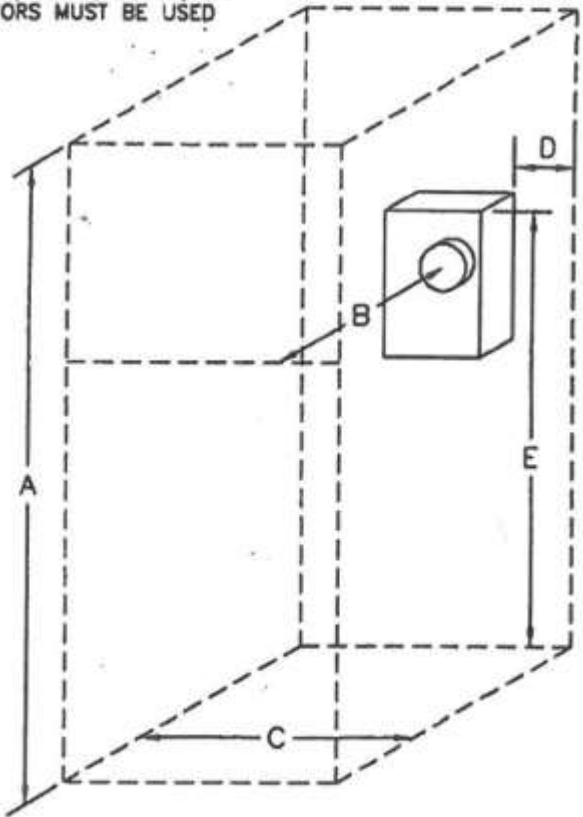

**UNACCEPTABLE METERBASE LOCATIONS**

- \* ELEVATED PLATFORMS.
- \* MOUNTED ON A CHIMNEY.
- \* UNDER DECKS LOWER THAN 7'.
- \* BELOW A GROUND FLOOR WINDOW.
- \* INSIDE FENCED AREAS WITH NO GATED ACCESS.
- \* LESS THAN 1' HORIZONTAL SEPARATION FROM GAS.
- \* INSIDE STRUCTURES EXCEPT IN APPROVED METER ROOMS.
- \* LESS THAN 3' FROM THE GAS METER VENT TO THE EDGE OF THE ELECTRIC METER GLASS.
- \* ANY AREA WHERE EQUIPMENT INHIBITS SAFE ACCESS OR OBSTRUCTS WORKING CLEARANCES.
- \* ANY AREA WHERE A DOOR MAY STRIKE THE METER/METERBASE.

BUILDERS GUIDE FOR  
INSTALLING METER BASES

**\*4 SCREWS (MINIMUM) #8 1-1/4" IN LENGTH**

**\*DRYWALL SCREWS ARE NOT ACCEPTABLE**

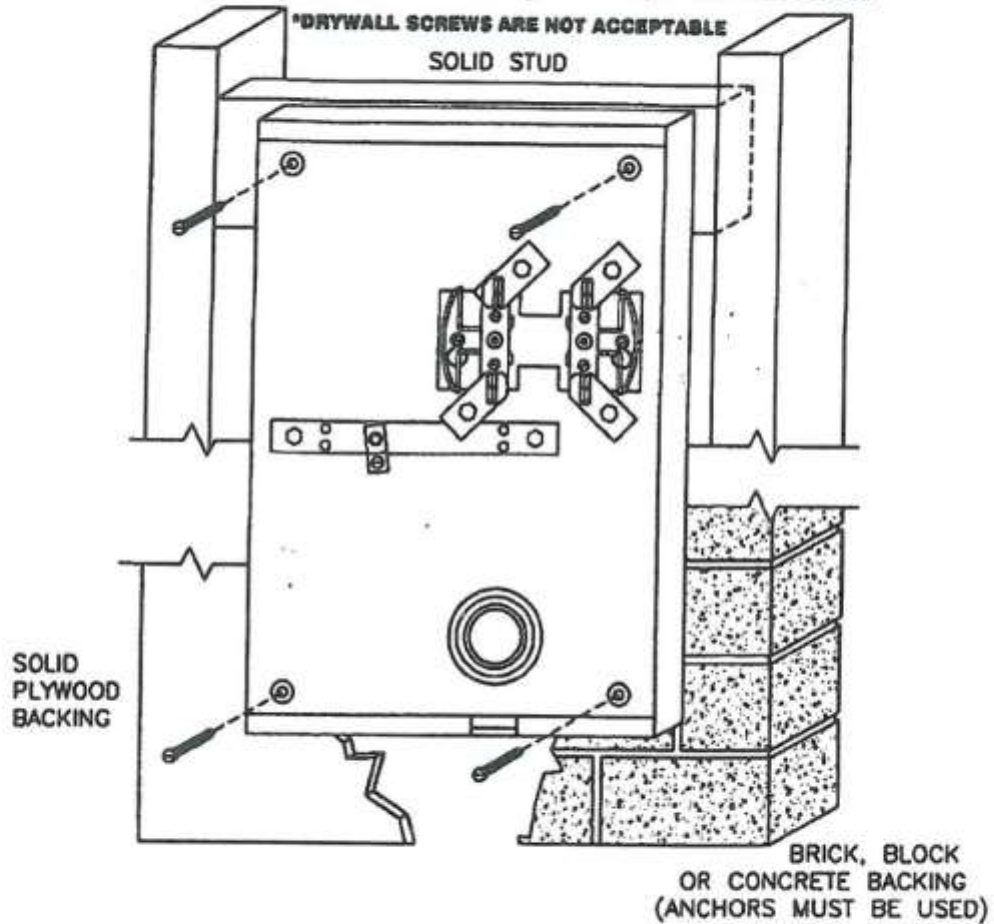

**UNACCEPTABLE METERBASE LOCATIONS**

- \* ELEVATED PLATFORMS.
- \* MOUNTED ON A CHIMNEY.
- \* UNDER DECKS LOWER THAN 7'.
- \* BELOW A GROUND FLOOR WINDOW.
- \* INSIDE FENCED AREAS WITH NO GATED ACCESS.
- \* LESS THAN 1' HORIZONTAL SEPARATION FROM GAS.
- \* INSIDE STRUCTURES EXCEPT IN APPROVED METER ROOMS.
- \* LESS THAN 3' FROM THE GAS METER VENT TO THE EDGE OF THE ELECTRIC METER GLASS.
- \* ANY AREA WHERE A DOOR MAY STRIKE THE METER/METERBASE.
- \* ANY AREA WHERE EQUIPMENT INHIBITS SAFE ACCESS OR OBSTRUCTS WORKING CLEARANCES.

BUILDERS GUIDE FOR  
METER BASE INSTALLATION STICKER

